



In vivo hemodynamics

1. Cardiac effects of mild hypothermia
2. Hemodynamics of systolic and diastolic heart failure

Heiner Post

Clinical dept. of Cardiology

Medical University of Graz, Austria



The New England Journal of Medicine

Copyright © 2002 by the Massachusetts Medical Society

VOLUME 346

FEBRUARY 21, 2002

NUMBER 8



MILD THERAPEUTIC HYPOTHERMIA TO IMPROVE THE NEUROLOGIC OUTCOME AFTER CARDIAC ARREST

THE HYPOTHERMIA AFTER CARDIAC ARREST STUDY GROUP*

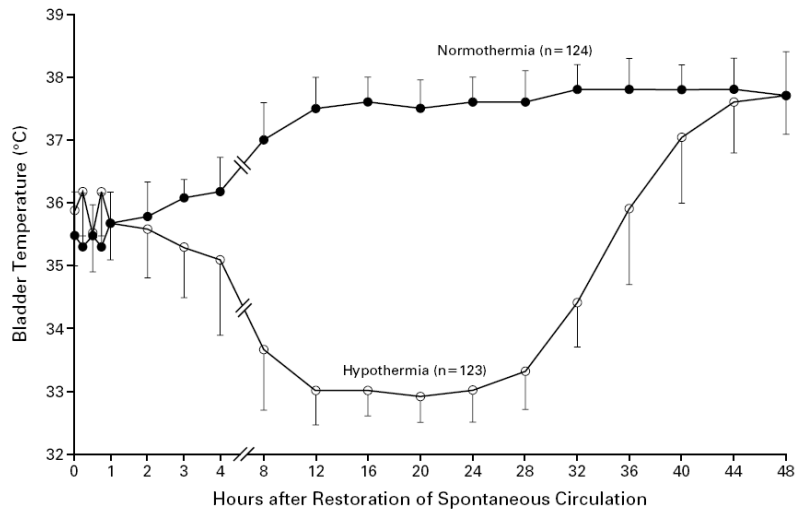

Figure 1. Bladder Temperature in the Normothermia and Hypothermia Groups.

The T bars indicate the 75th percentile in the normothermia group and the 25th percentile in the hypothermia group. The target temperature in the hypothermia group was 32°C to 34°C, and the duration of cooling was 24 hours. Only patients with recorded temperatures were included in the analysis.



Medizinische Universität Graz

24 h MH (33°C) after cardiac arrest

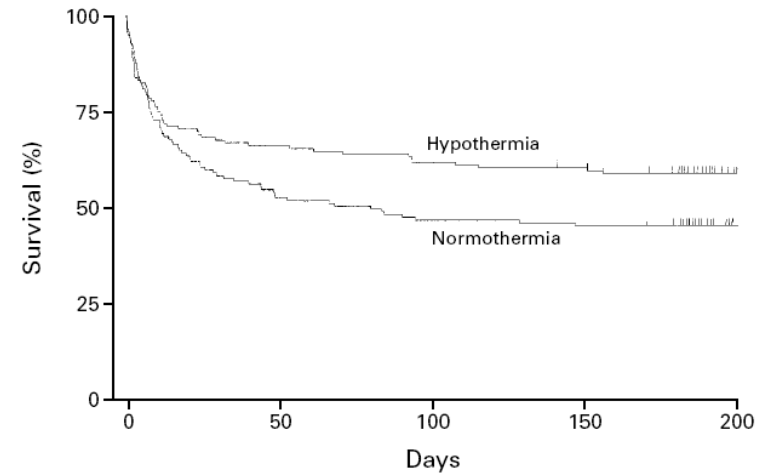

TABLE 2. NEUROLOGIC OUTCOME AND MORTALITY AT SIX MONTHS.

OUTCOME	NORMOTHERMIA	HYPOTHERMIA	RISK RATIO (95% CI)*	P VALUE†
	no./total no. (%)			
Favorable neurologic outcome‡	54/137 (39)	75/136 (55)	1.40 (1.08–1.81)	0.009
Death	76/138 (55)	56/137 (41)	0.74 (0.58–0.95)	0.02

*The risk ratio was calculated as the rate of a favorable neurologic outcome or the rate of death in the hypothermia group divided by the rate in the normothermia group. CI denotes confidence interval.

†Two-sided P values are based on Pearson's chi-square tests.

‡A favorable neurologic outcome was defined as a cerebral-performance category of 1 (good recovery) or 2 (moderate disability). One patient in the normothermia group and one in the hypothermia group were lost to neurologic follow-up.

Oscar Langendorff

(*1853, †1908)



Medizinische Universität Graz



(Aus dem physiologischen Institut in Rostock.)

Untersuchungen am überlebenden Säugethierherzen.

Mitgetheilt von

O. Langendorff.

II. A b h a n d l u n g.

Ueber den Einfluss von Wärme und Kälte auf das Herz der warmblütigen Thiere.

(Nach Versuchen von O. Langendorff und Dr. Czeslaw Nawrocki.)

Hierzu Tafel V, VI, VII u. VIII und 14 Textfiguren.

In meiner ersten Mittheilung über das isolirte Warmblüterherz (1) habe ich gezeigt, dass es gerade so wie das Froschherz von der Temperatur beeinflusst wird. Aenderte man die Wärme des durch das Koronarsystem fließenden Blutes, so änderte sich entsprechend die Schlagzahl; dem rapiden Ablauf der Zusammenziehungen des warmen stand die träge Kontraktion des abgekühlten Herzens gegenüber. Ich zeigte ferner, dass das Herz noch bei Speisung mit stark abgekühltem Blut seine Schläge nicht einstellt.

Langendorff O (1897) Untersuchungen am überlebenden Säugetierherzen. Über den Einfluss von Wärme und Kälte auf das Herz der warmblütigen Tiere. Pflügers Arch 66: 355–400

MH is a positive inotrope



Isolated human heart muscle strips

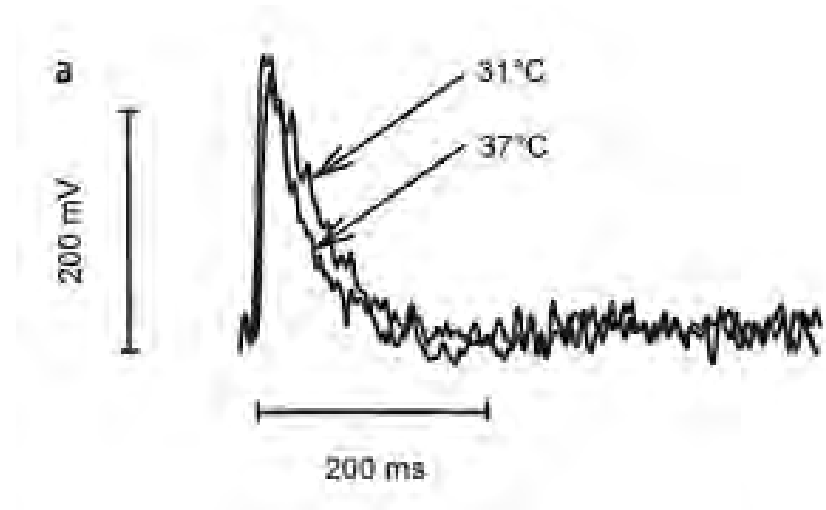
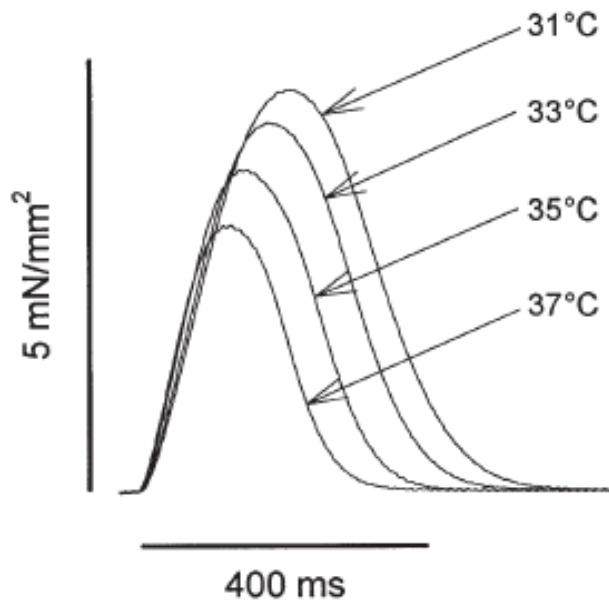

MH in normal pigs:
improved systolic, but decreased diastolic function

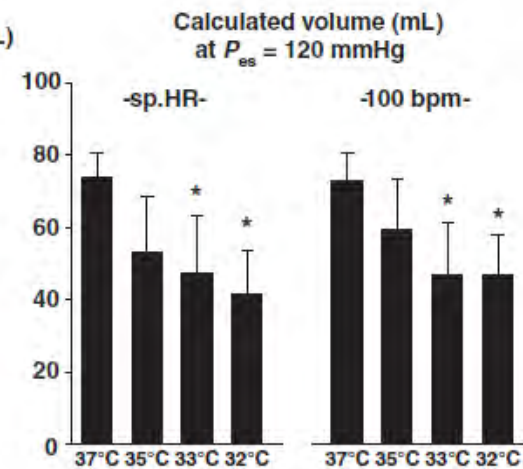
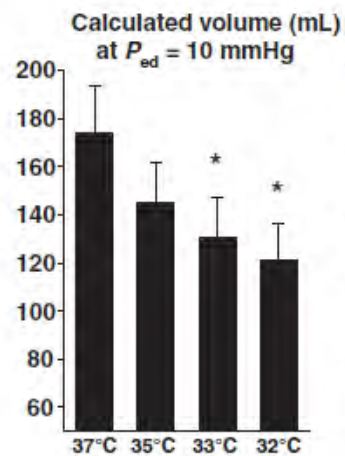
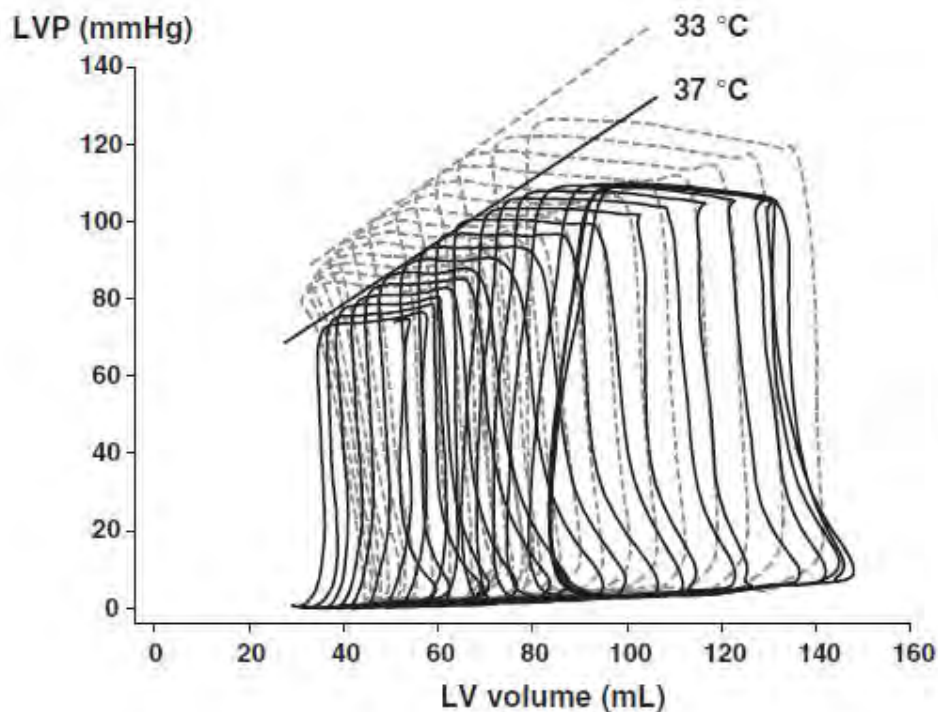
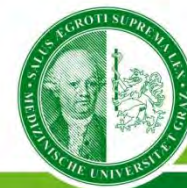

- 16 female, landrace pigs (63.6±1.8 kg)
- closed chest
- Swan-Ganz catheter
- PV catheter
- right atrial pacing probe
- aortic ballon catheter
- intravascular cooling device

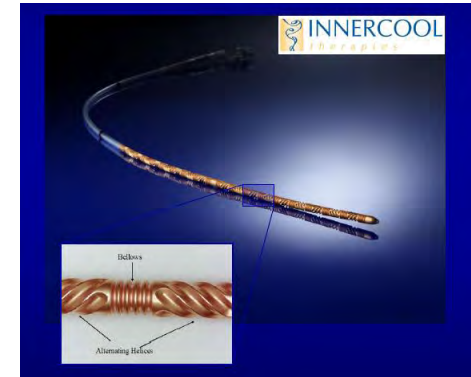

MH after cardiac arrest



Medizinische Universität Graz

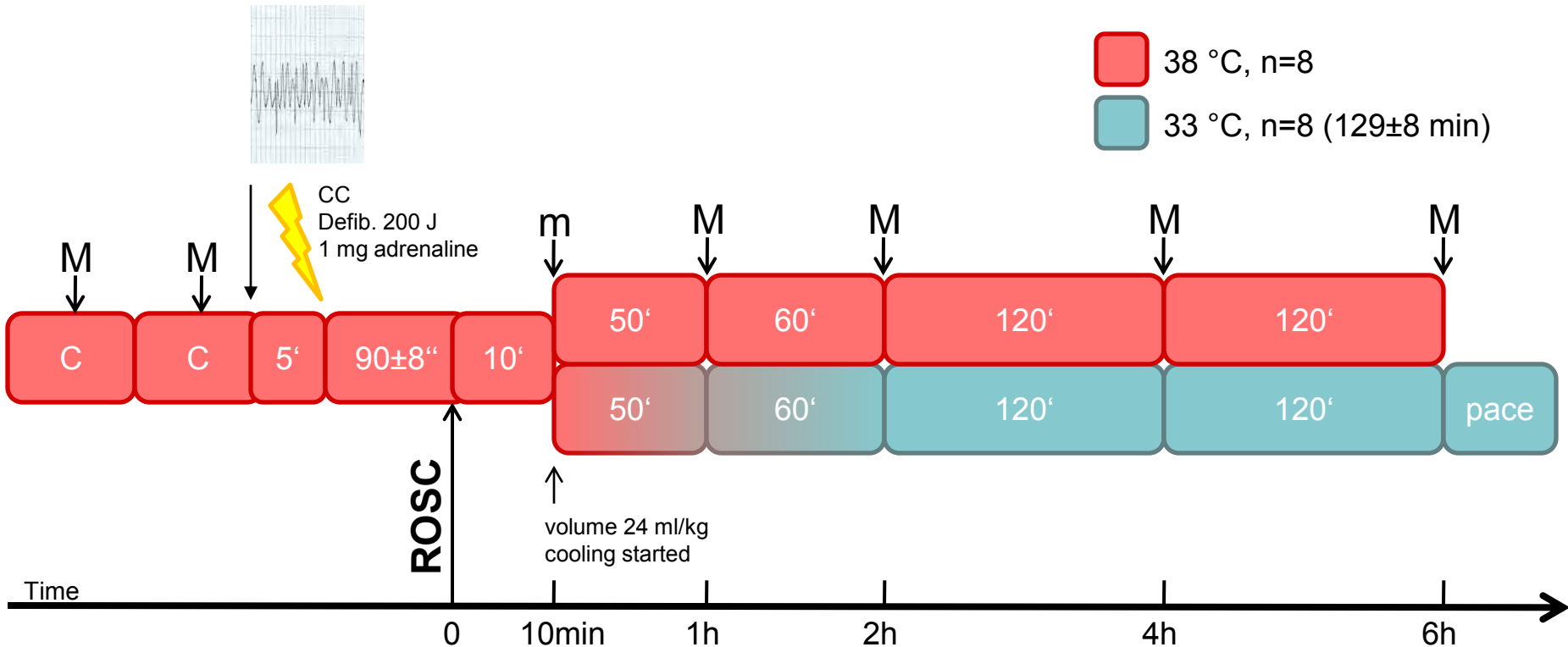

M: saline, CO, BGA art./ven., blood samples, aortic occlusion
m: saline, CO, BGA art./ven., blood samples

MH after cardiac arrest



Medizinische Universität Graz

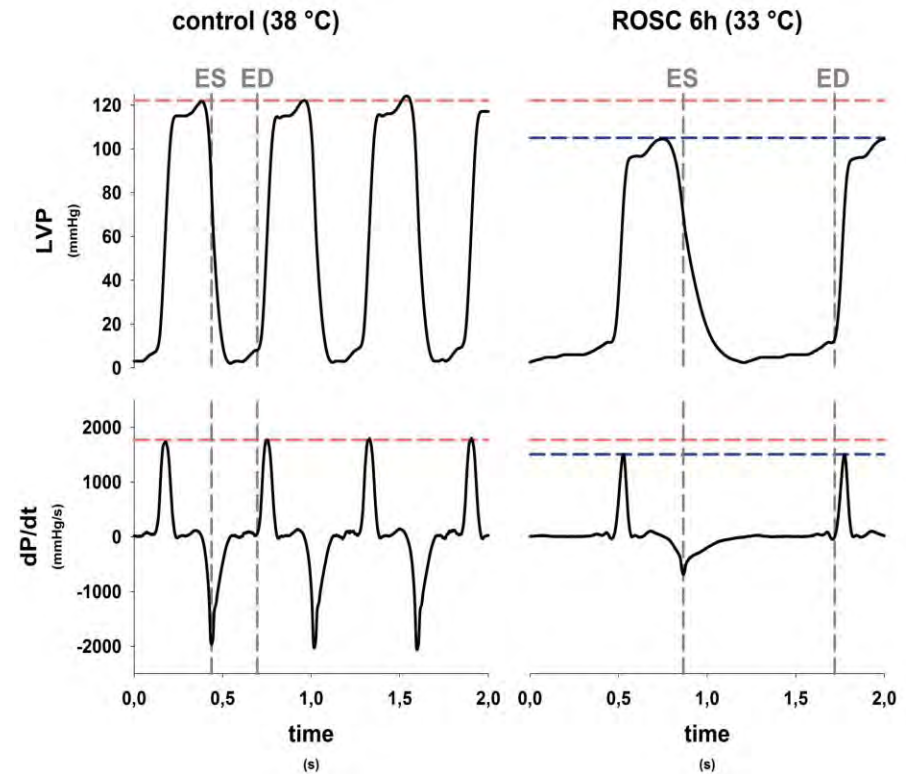
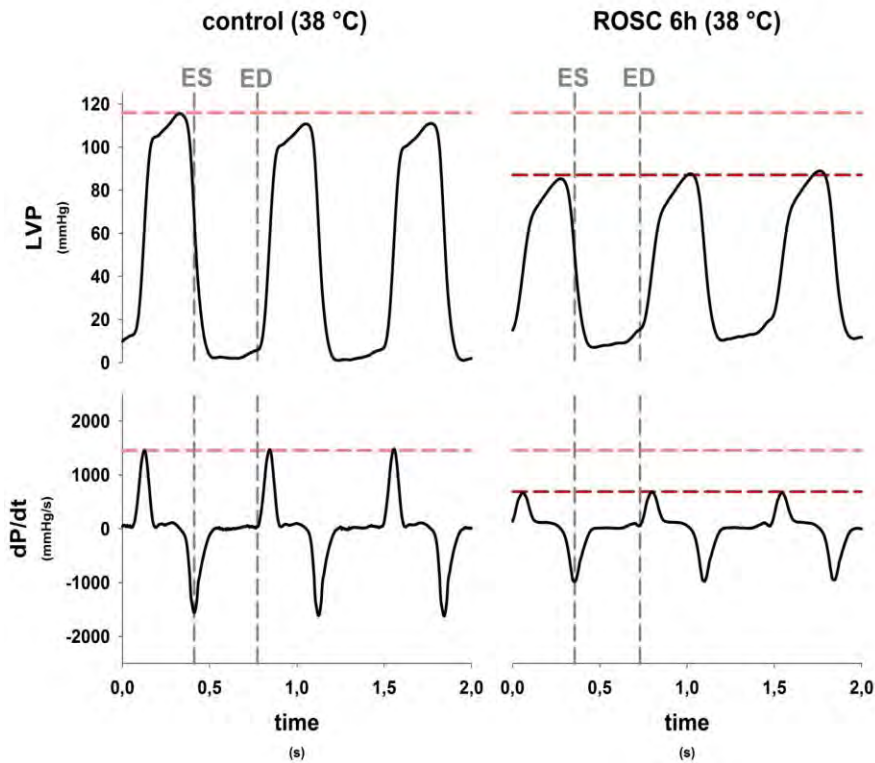

MH after cardiac arrest

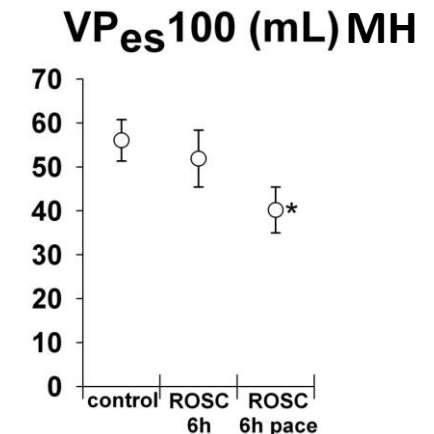
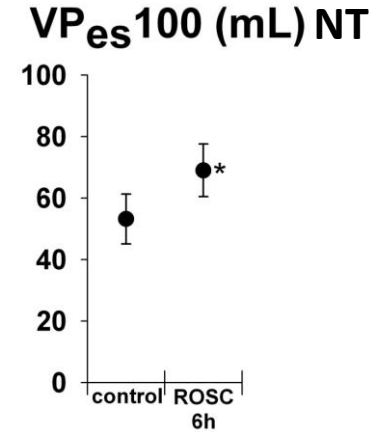
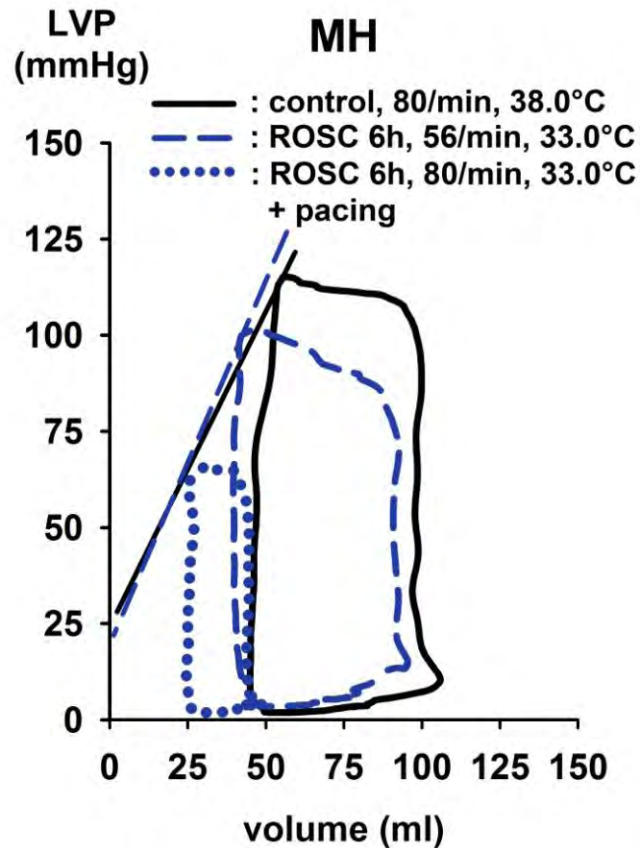
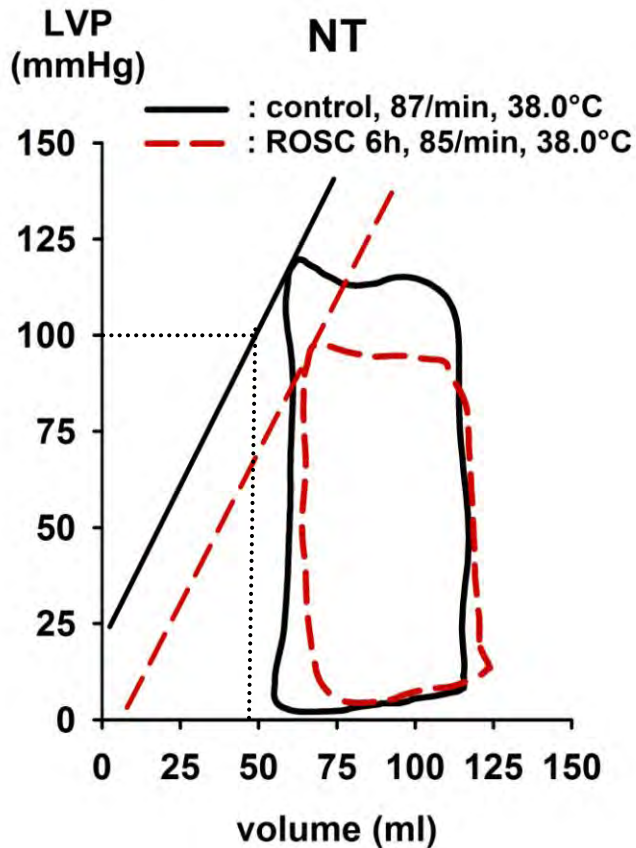

MH after cardiac arrest



Medizinische Universität Graz

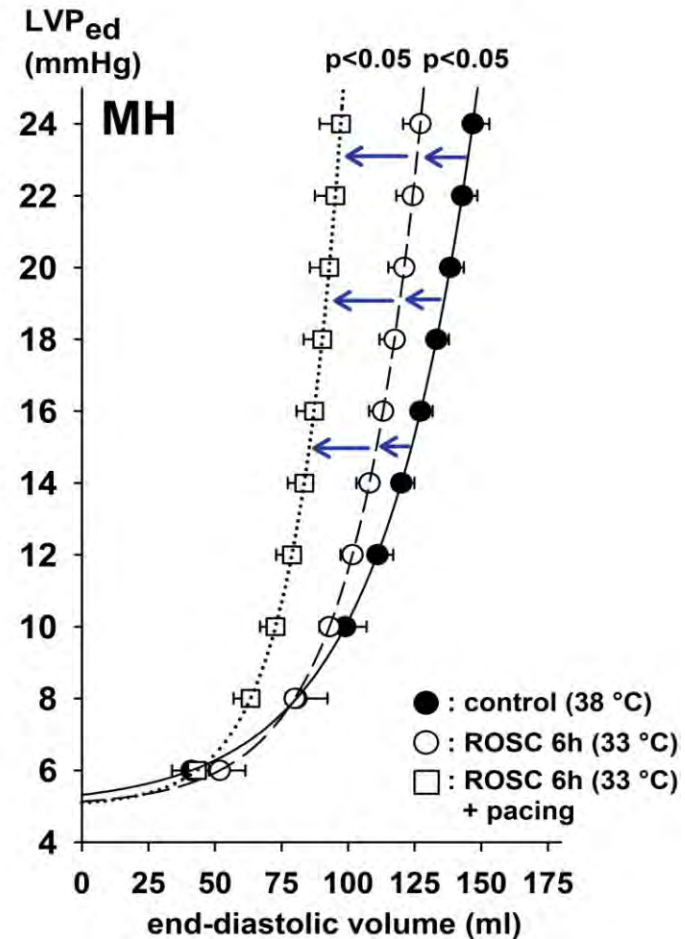
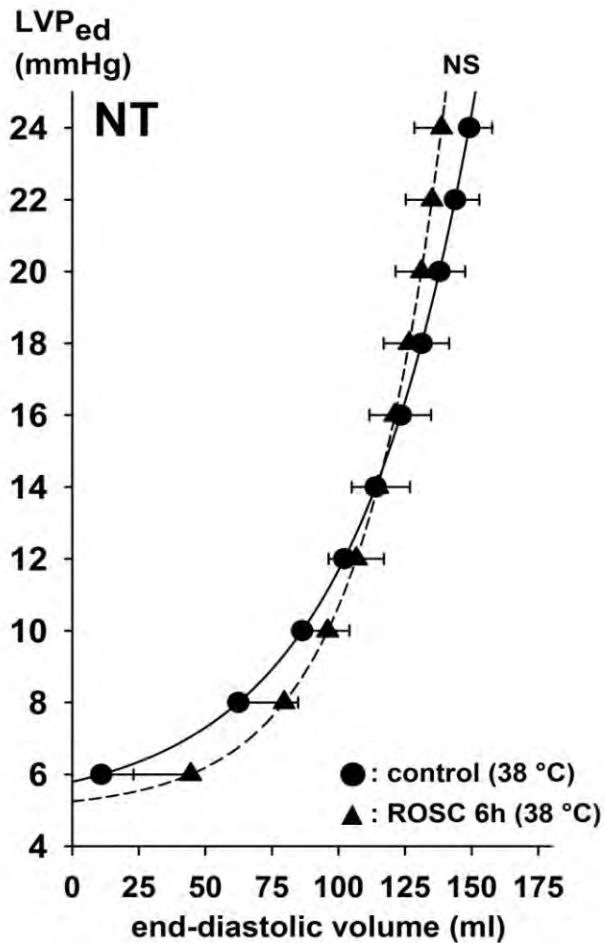

Schwarzl et al., Acta Physiol 2011

MH after cardiac arrest



Medizinische Universität Graz

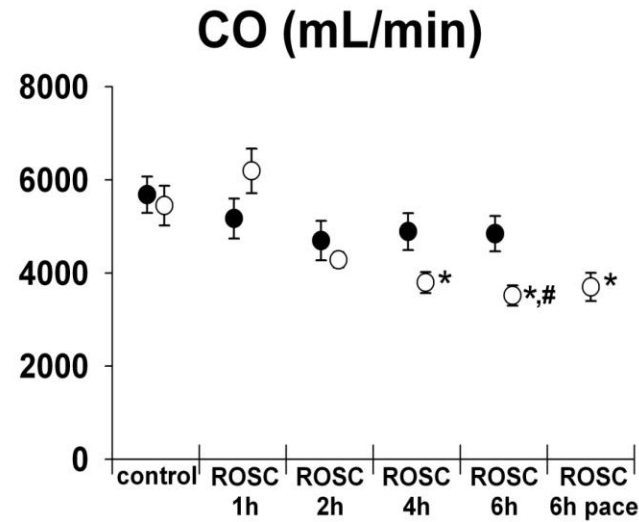
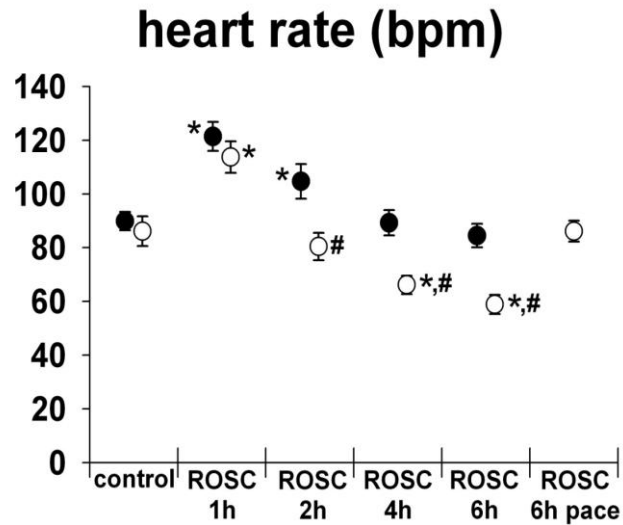

● NT (38 °C)
○ MH (33 °C)
* p < 0.05 vs. control
p < 0.05 vs. NT

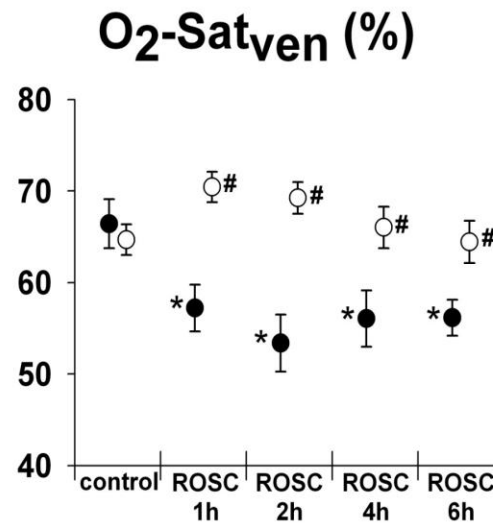
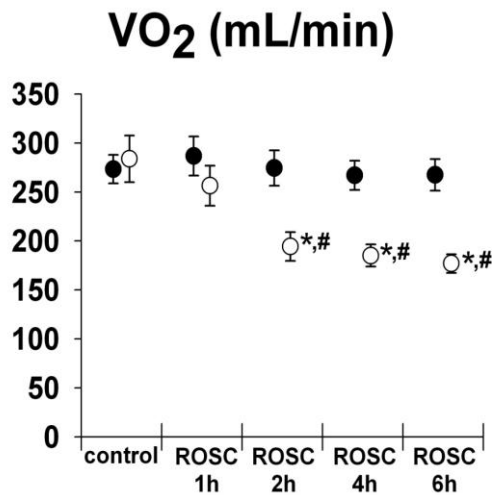

Schwarzl et al., Acta Physiol 2011

Heart rate variability



Poincaré plot

control (38 °C)

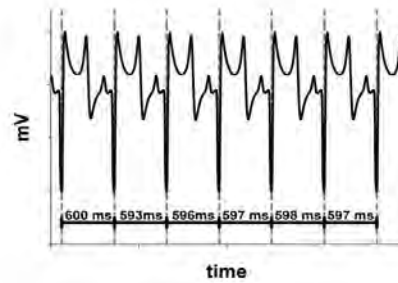
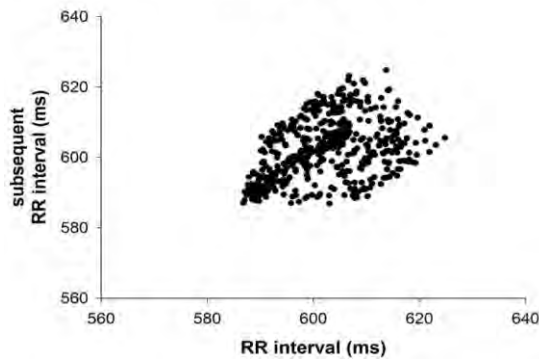

1

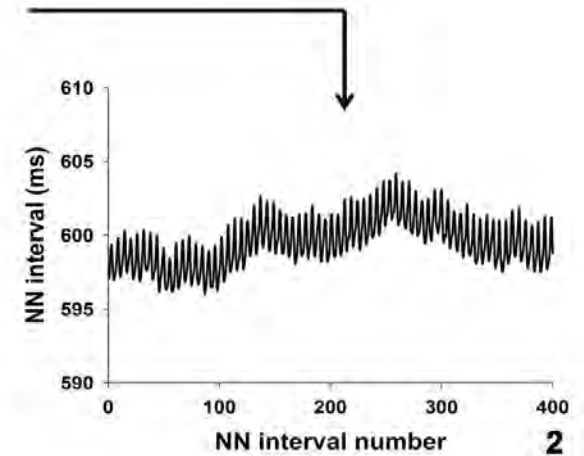

2

ROSC + 1h (38 °C)

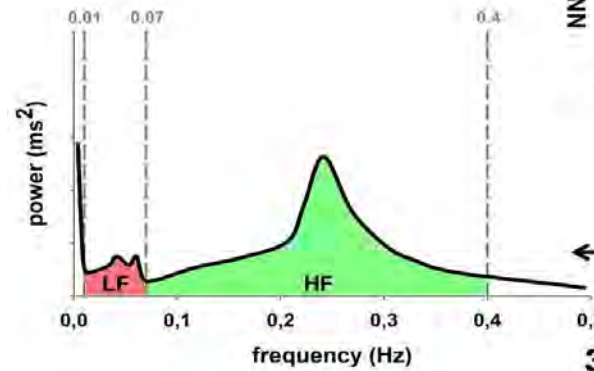
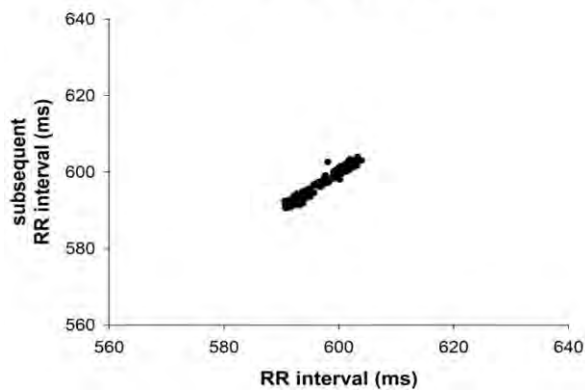

3

MH after cardiac arrest



Medizinische Universität Graz

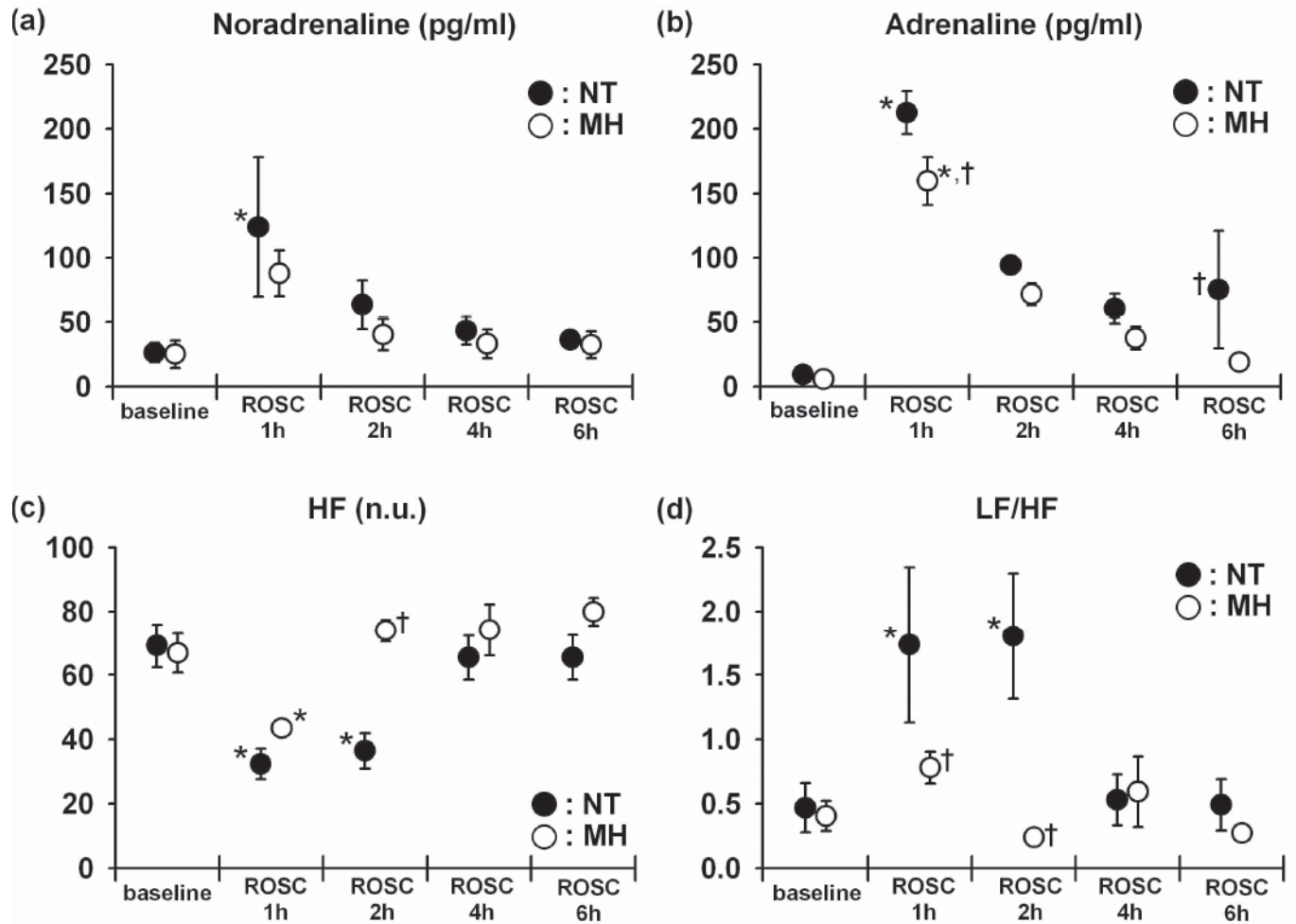

Schwarzl et al., Acta Physiol 2011

MH after cardiac arrest



Medizinische Universität Graz

- increases contractility
- decreases diastolic function – compensated by bradycardia
- improves oxygen-supply demand
- does not potentiate sympathetic activation

NO-reflow myocardial infarction



Medizinische Universität Graz

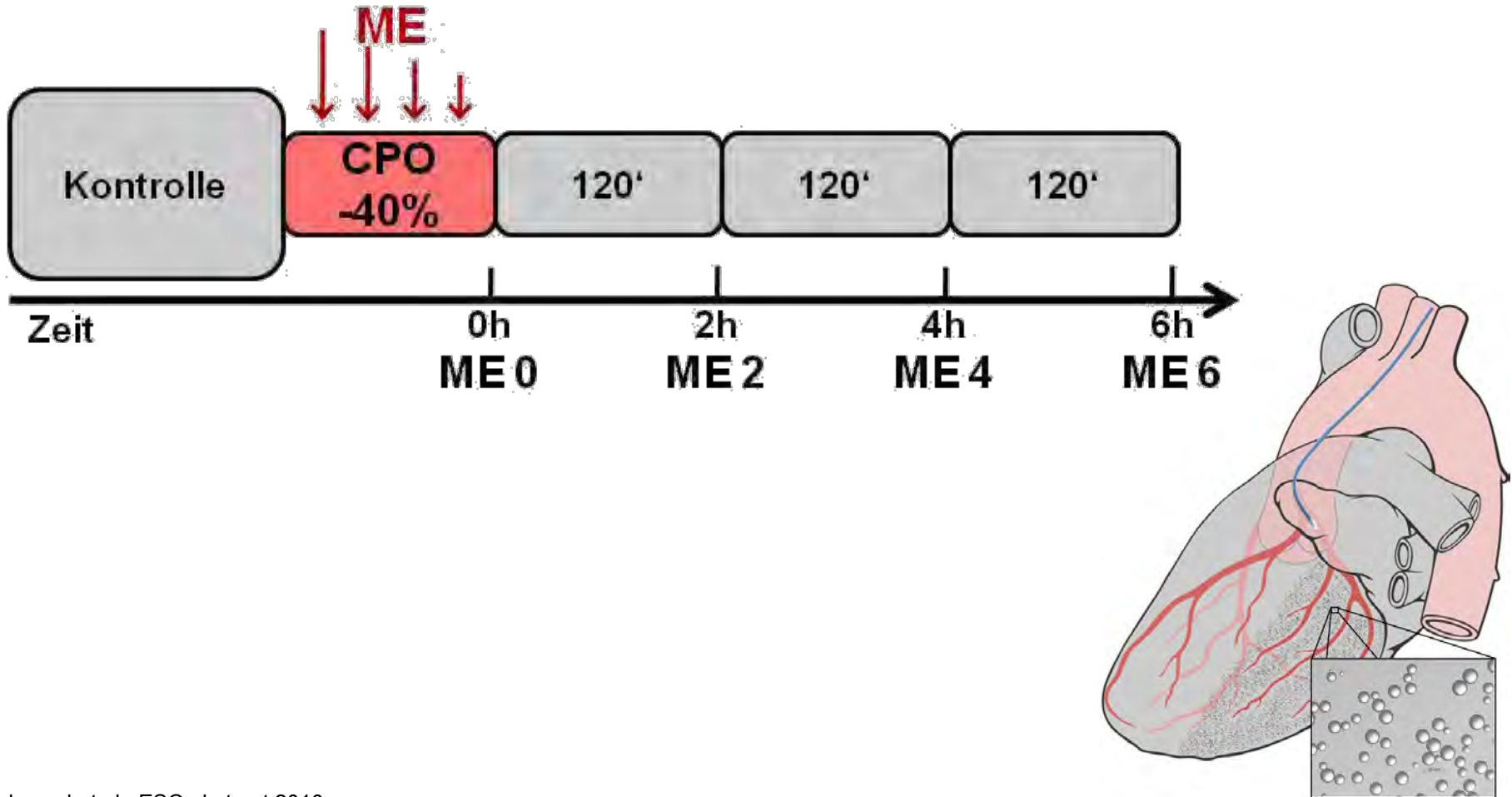

Acute heart failure after CME



Medizinische Universität Graz

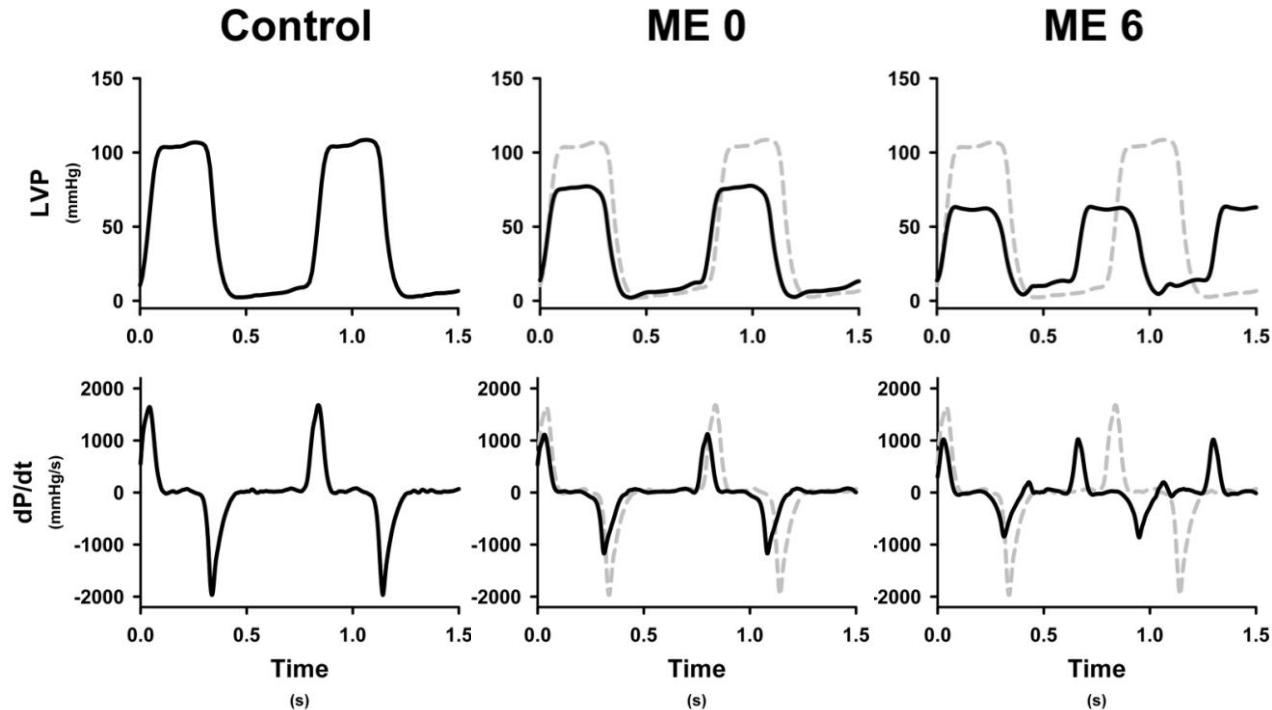

* p<0.05 vs. control
p<0.05 vs. ME 0

heart rate (bpm)

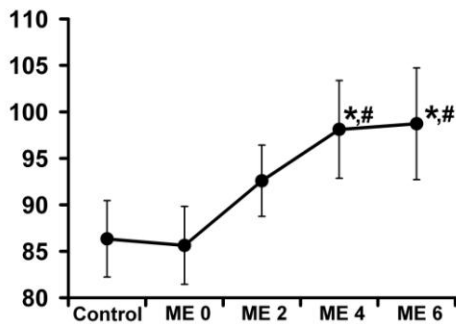

Cardiac Power Output (W)

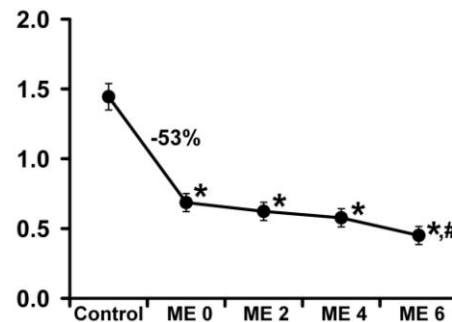

mixed venous sO₂ (%)

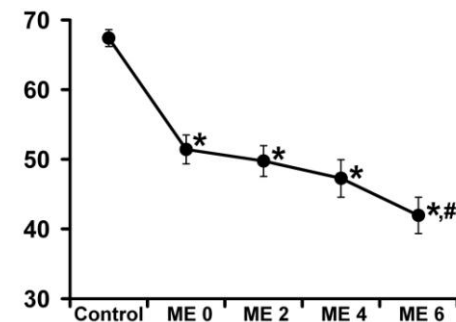

Acute systolic and diastolic heart failure after CME



Medizinische Universität Graz

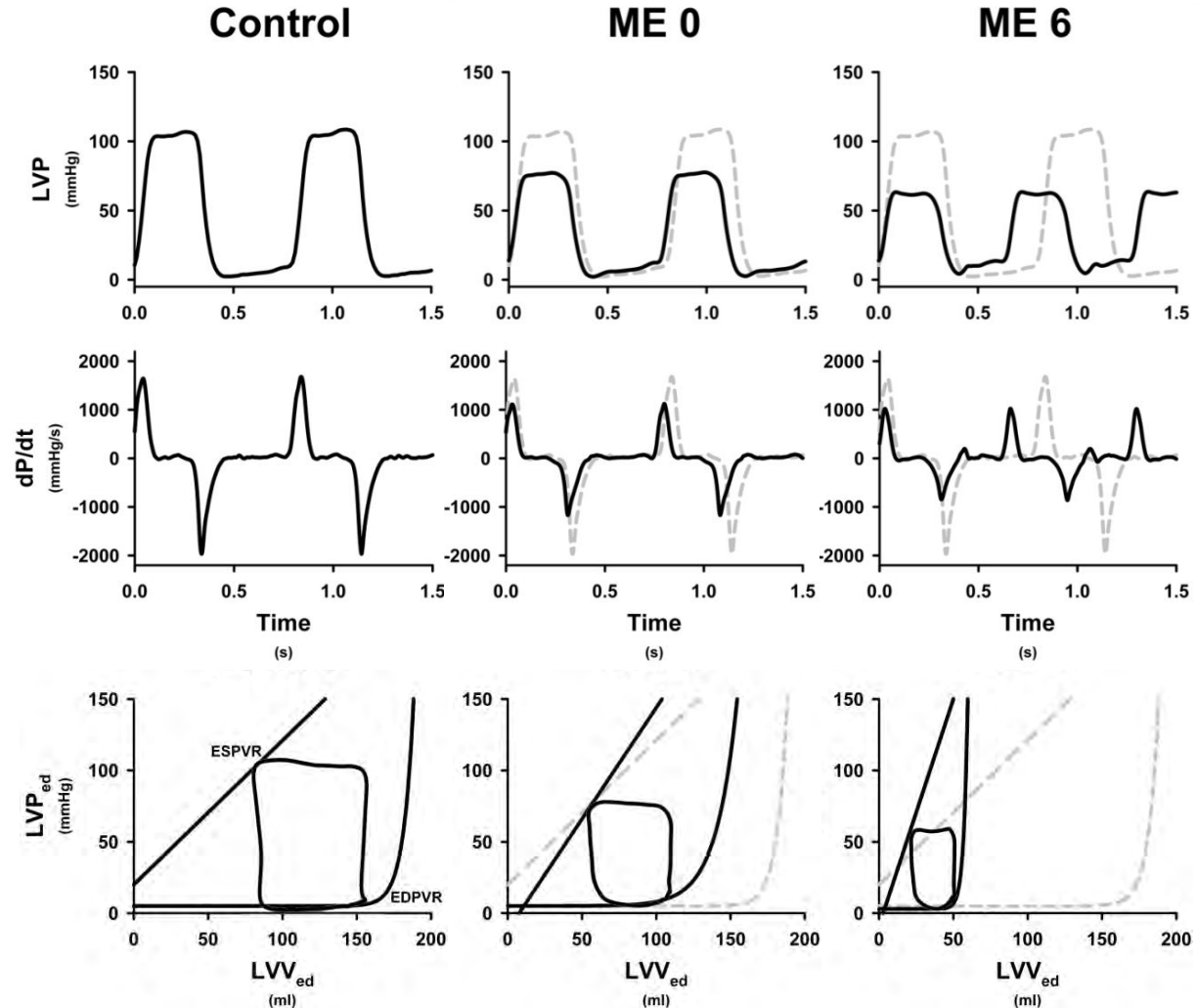

Schwarzl et al., ESC abstract 2011

Ejection fraction after CME

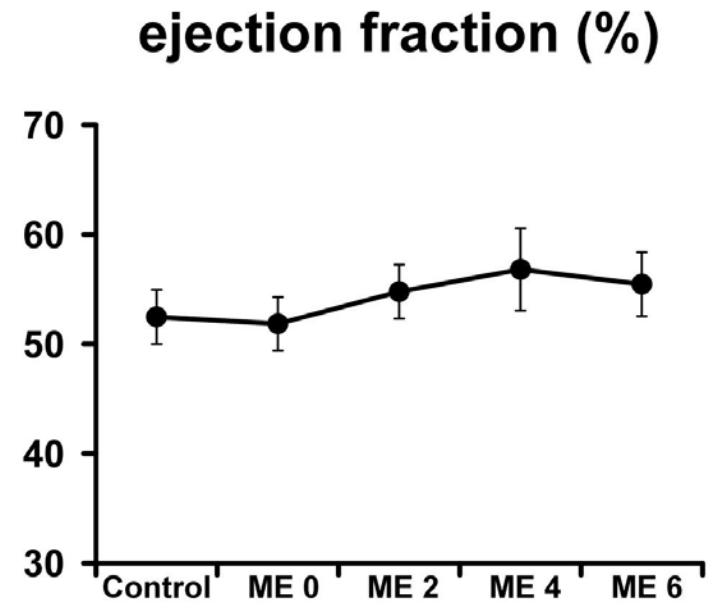
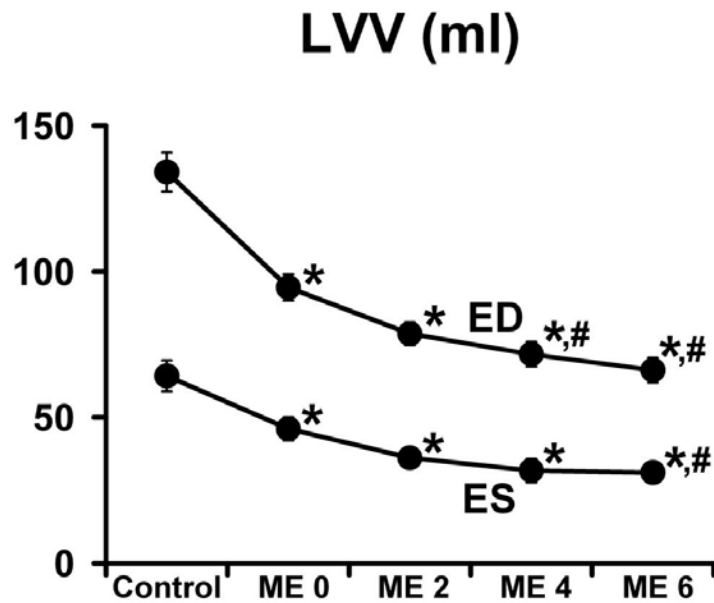

Pressure-time derived indices



Medizinische Universität Graz

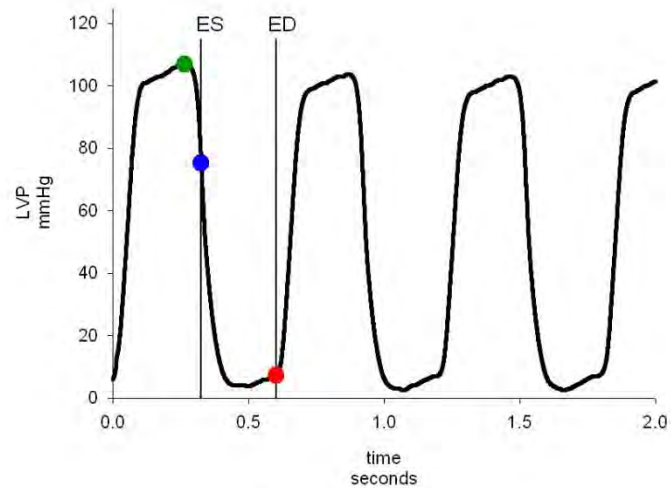

- LVP_{max}
- LVP_{es}
- LVP_{ed}
- dP/dt_{max}
- dP/dt_{min}
- τ

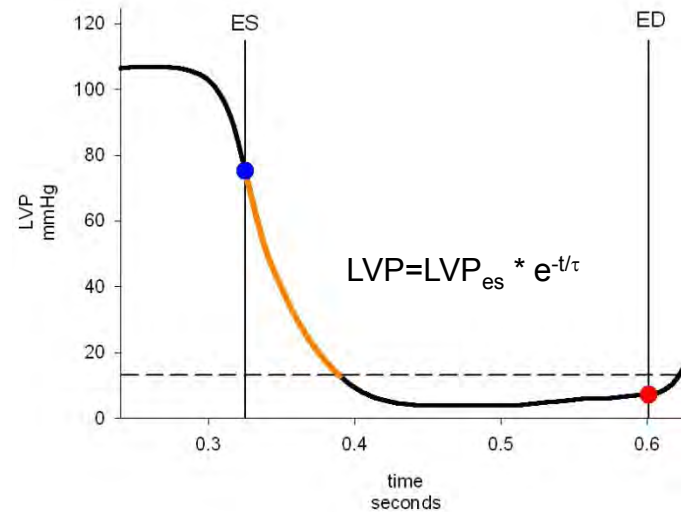
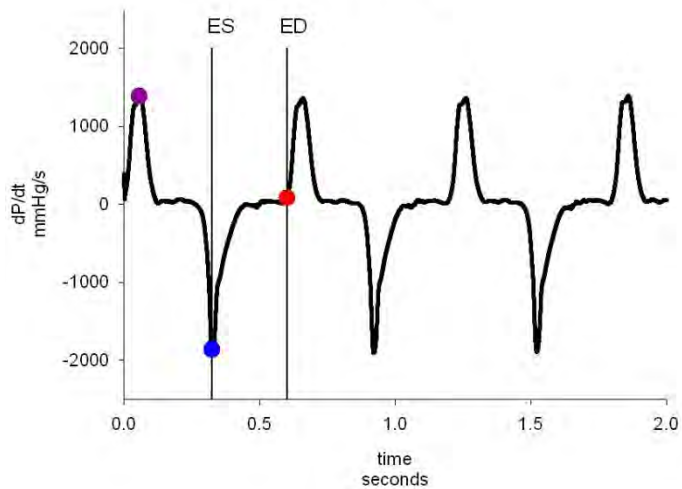

Active LV relaxation after CME

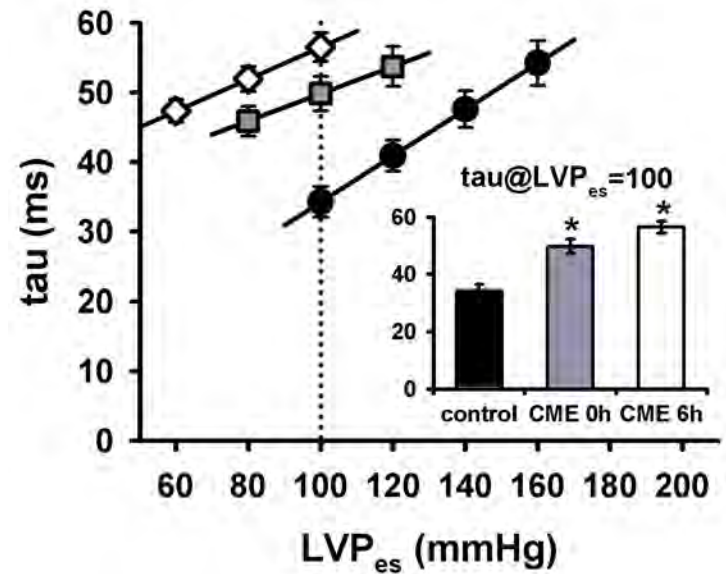
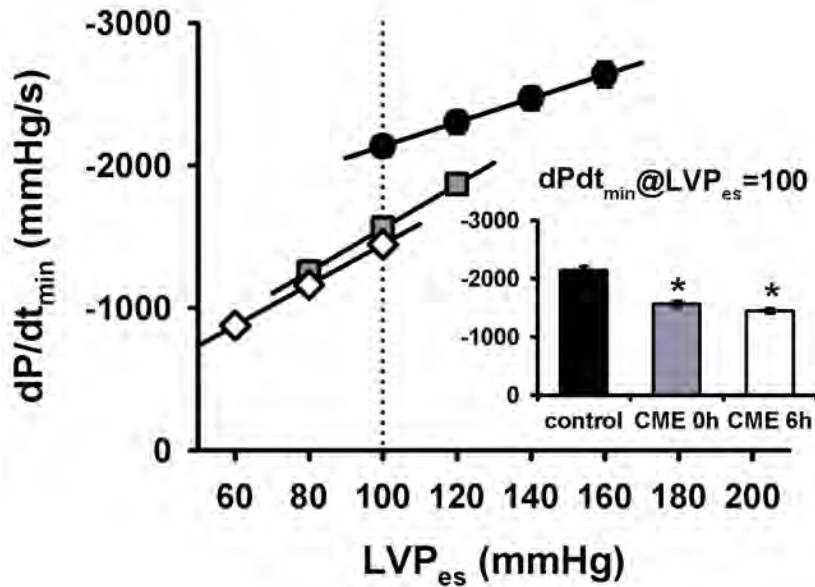

Pressure-volume derived indices

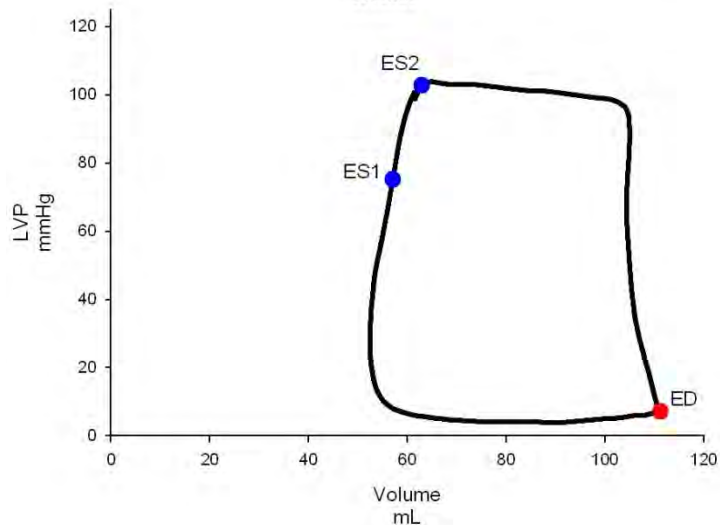
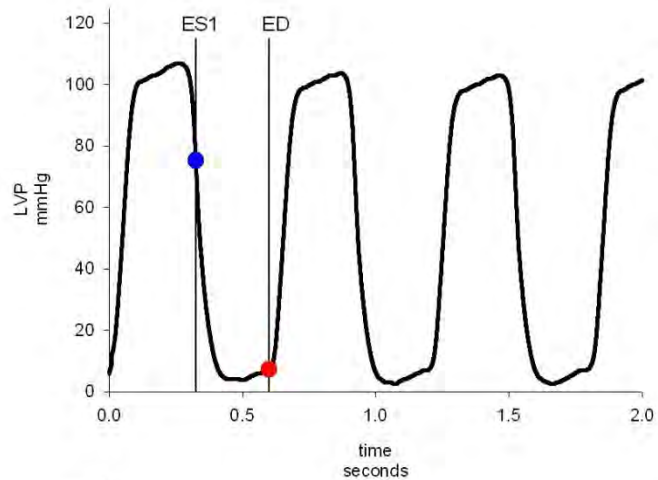

- LVP_{es}, V_{es}
- LVP_{ed}, V_{ed}
- end-systolic pressure-volume relationship (ESPVR, $VP_{es} 100$)

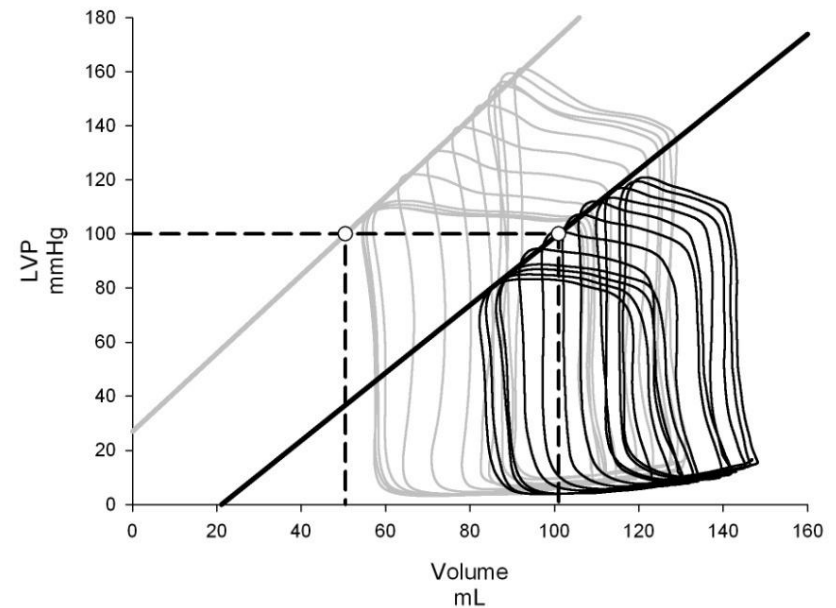

Acute systolic and diastolic heart failure after CME: how to treat?



Medizinische Universität Graz

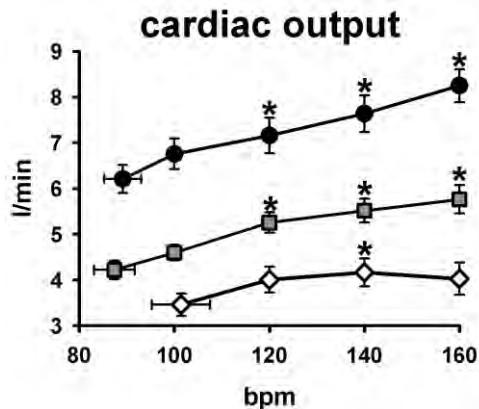
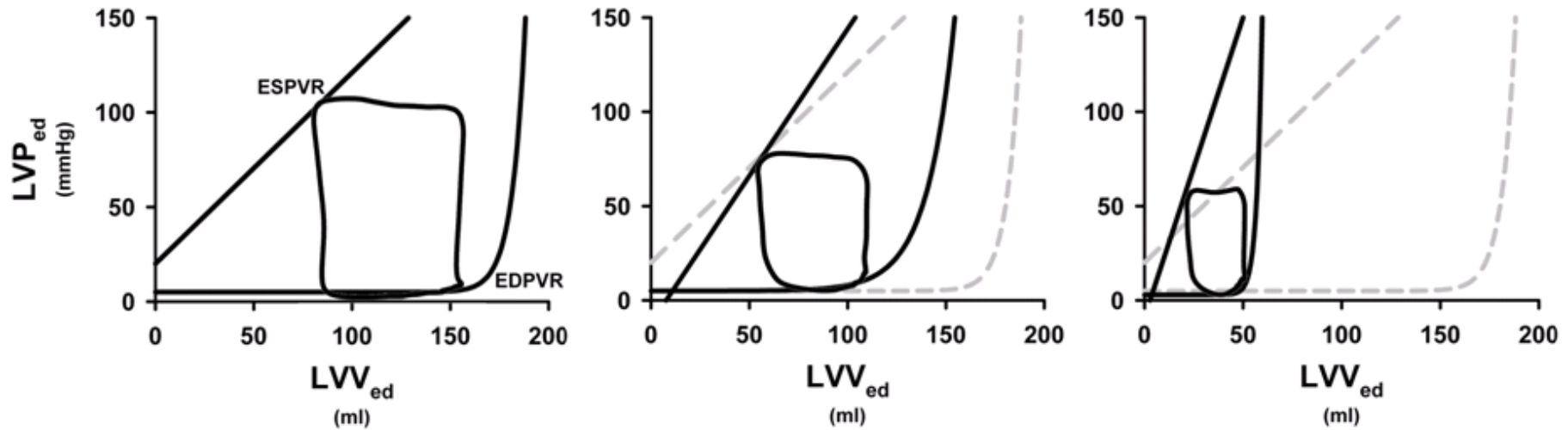

Increase preload – pulmonary edema
 Increase inotropy – ES volume already small
 Decrease afterload – ES volume is already small
 Increase heart rate – no effect
 IABP – no reflow, ES volume is already small

PV-relationships after CME

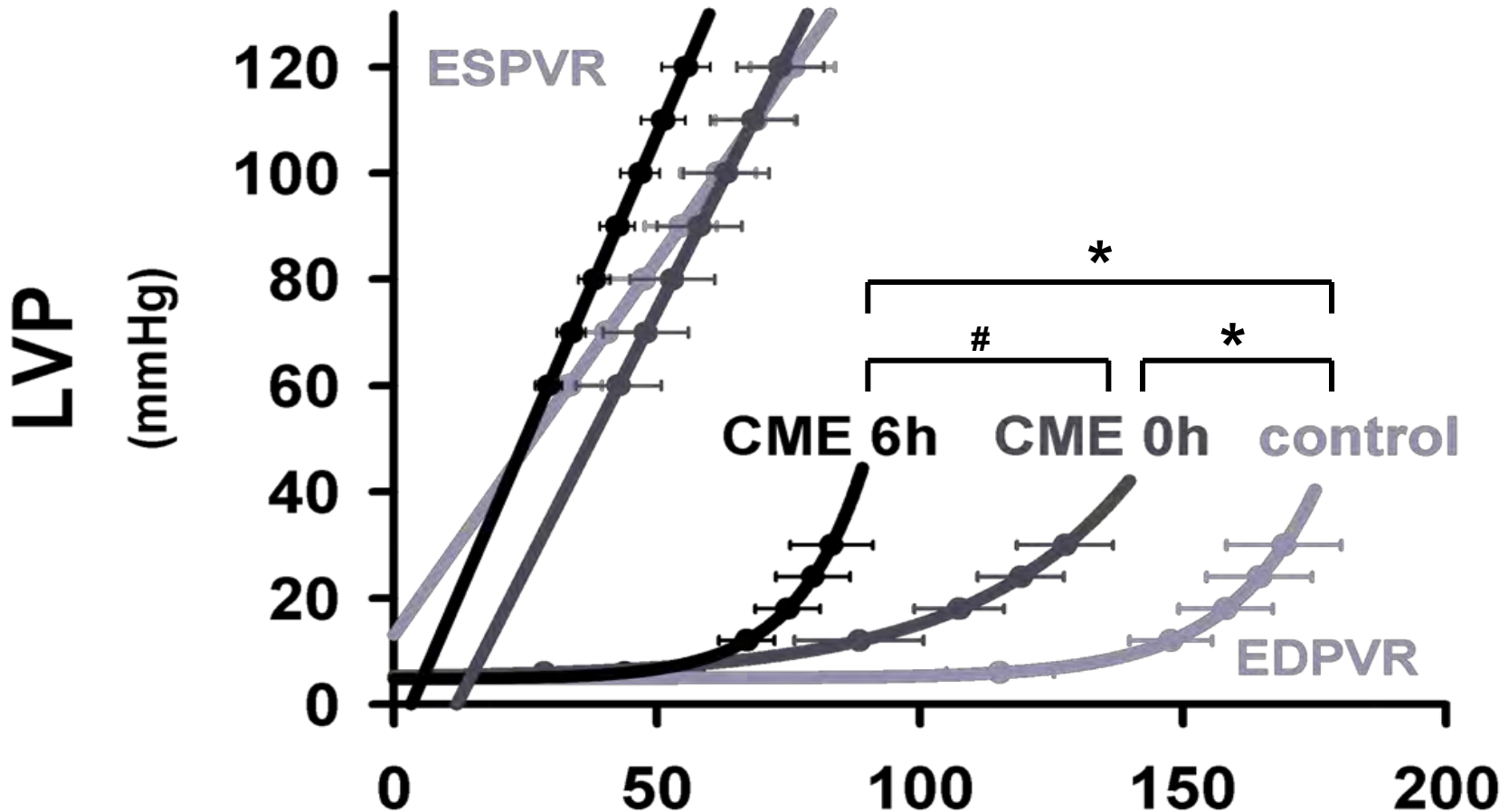

Effect of cooling on acute heart failure after CME

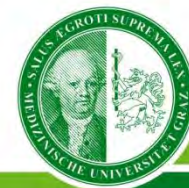

Medizinische Universität Graz

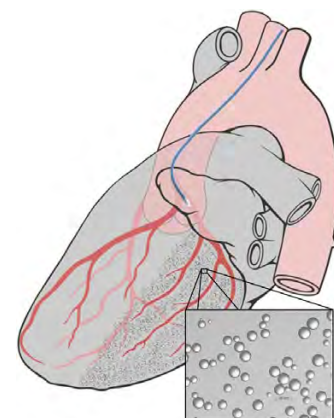
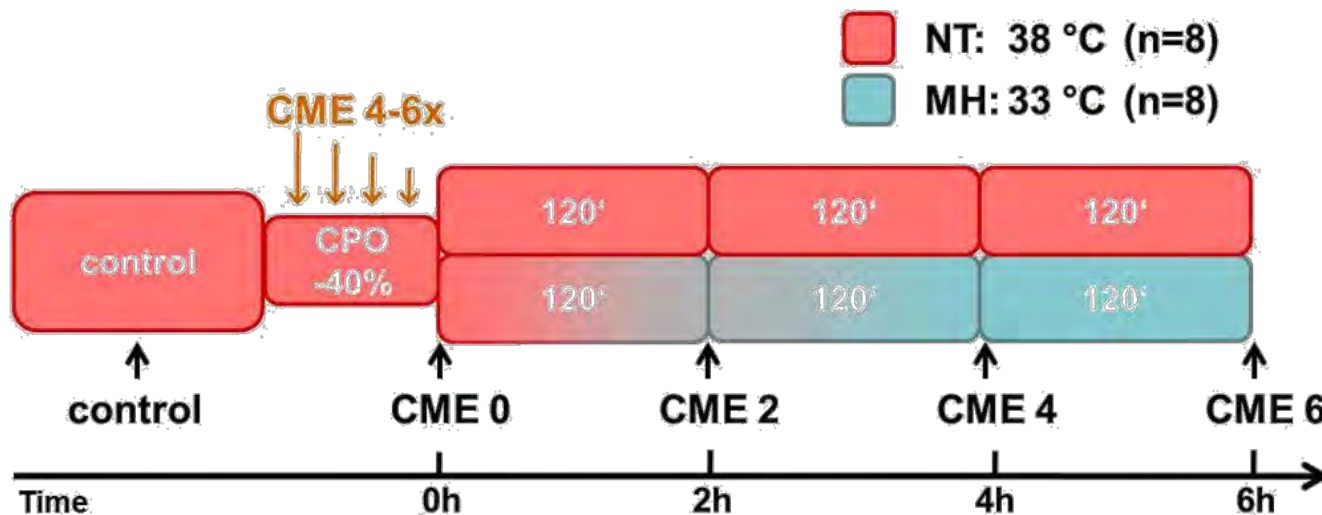

Schwarzl et al., ESC abstract 2011

Effect of cooling on acute heart failure after CME



Medizinische Universität Graz

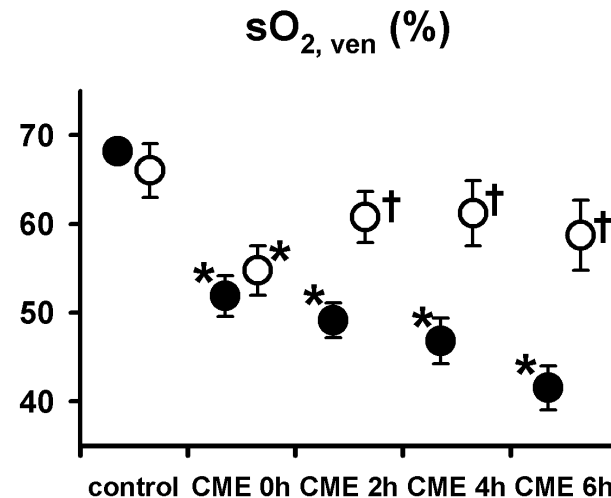
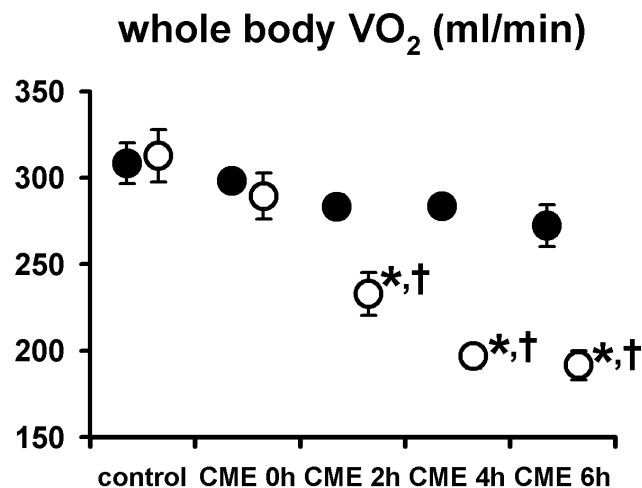
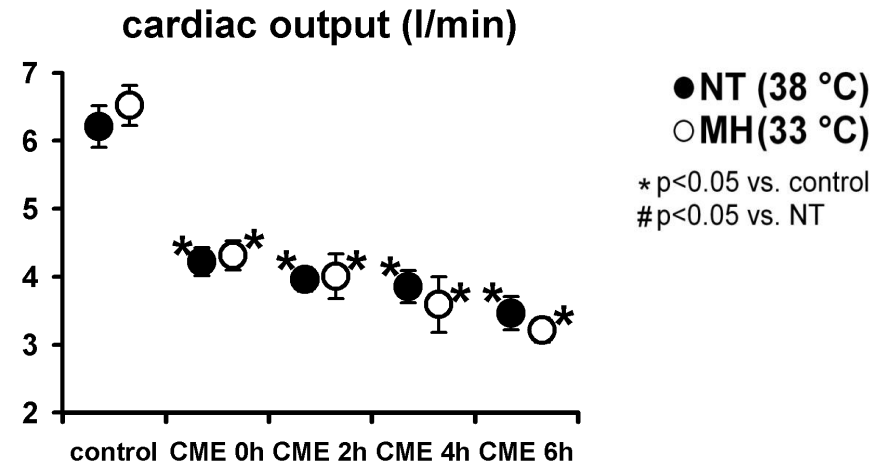
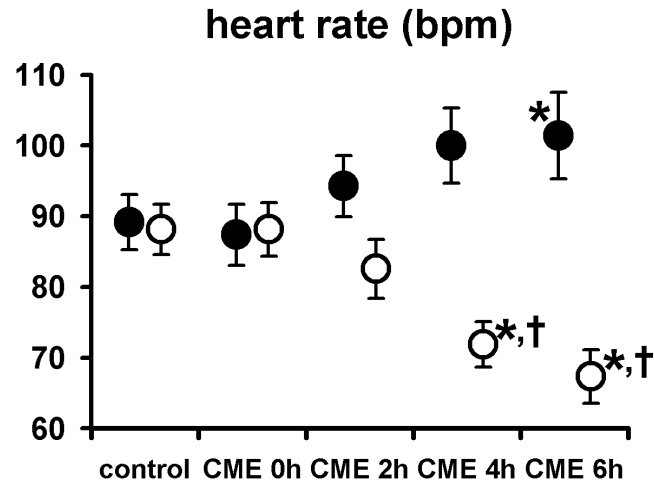

Effect of cooling on acute heart failure after CME: PV-relationships



Medizinische Universität Graz

38,0°C

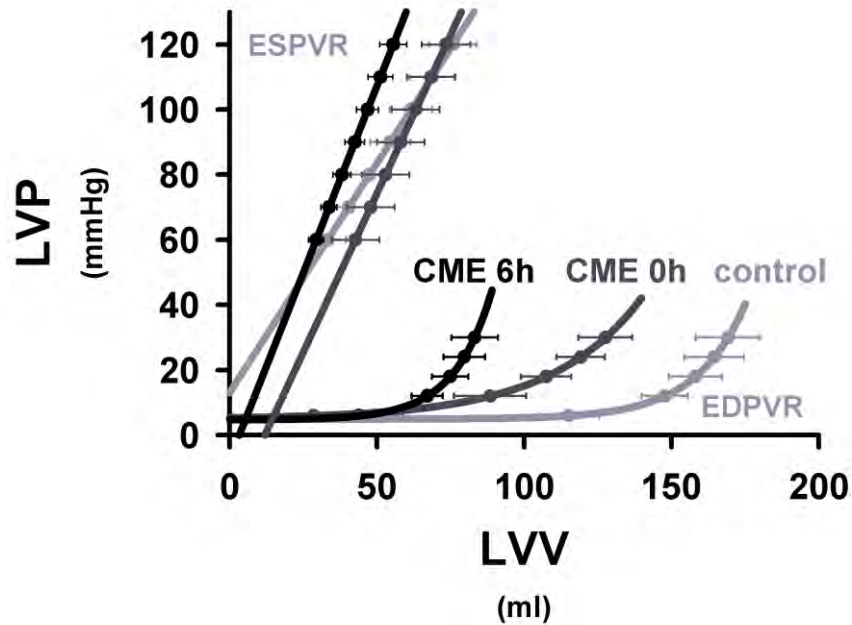

33,0°C after CME

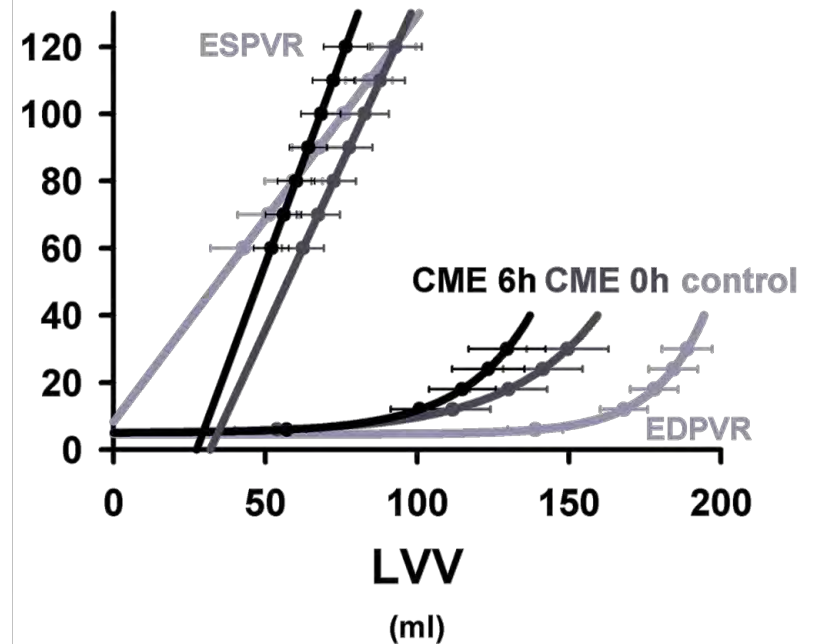

Schwarzl et al., ESC abstract 2011

Effect of cooling on acute heart failure after CME: challenging relaxation



Medizinische Universität Graz

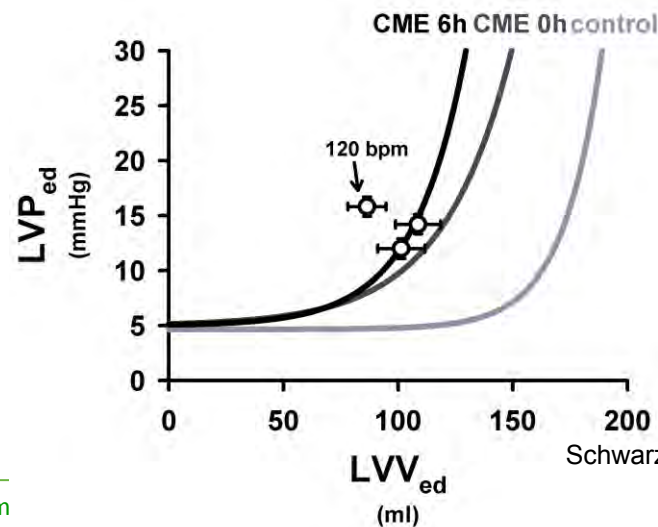
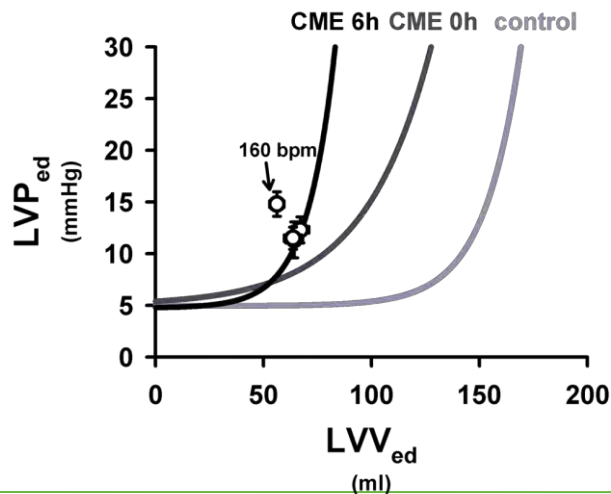
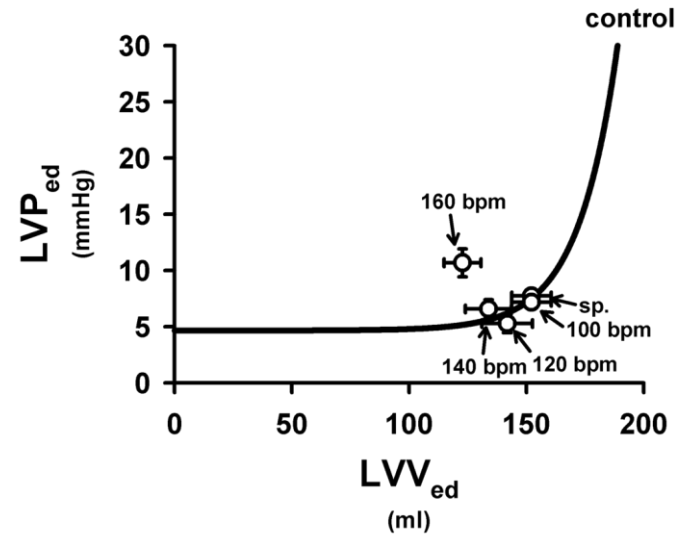
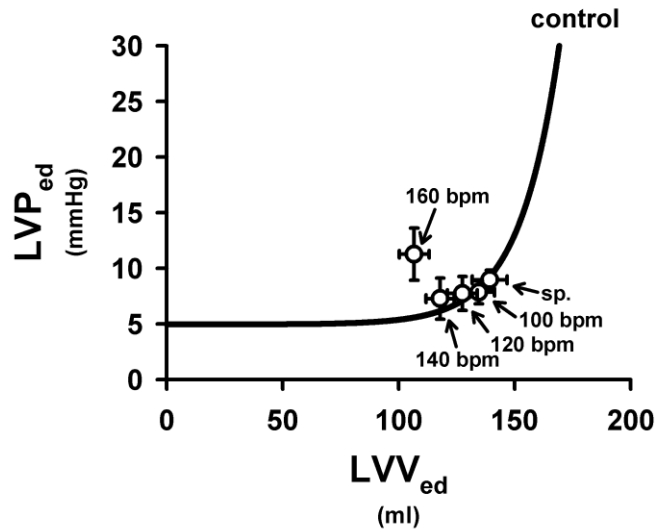

Schwarzl et al., ESC abstract 2011

Mild hypothermia in acute heart failure



Medizinische Universität Graz

O_2 -demand

hypothermia



O_2 -delivery

preload
inotropics
pacing
devices:
(IABP, Impella
ECMO)

Sepsis/inflammation model



Medizinische Universität Graz

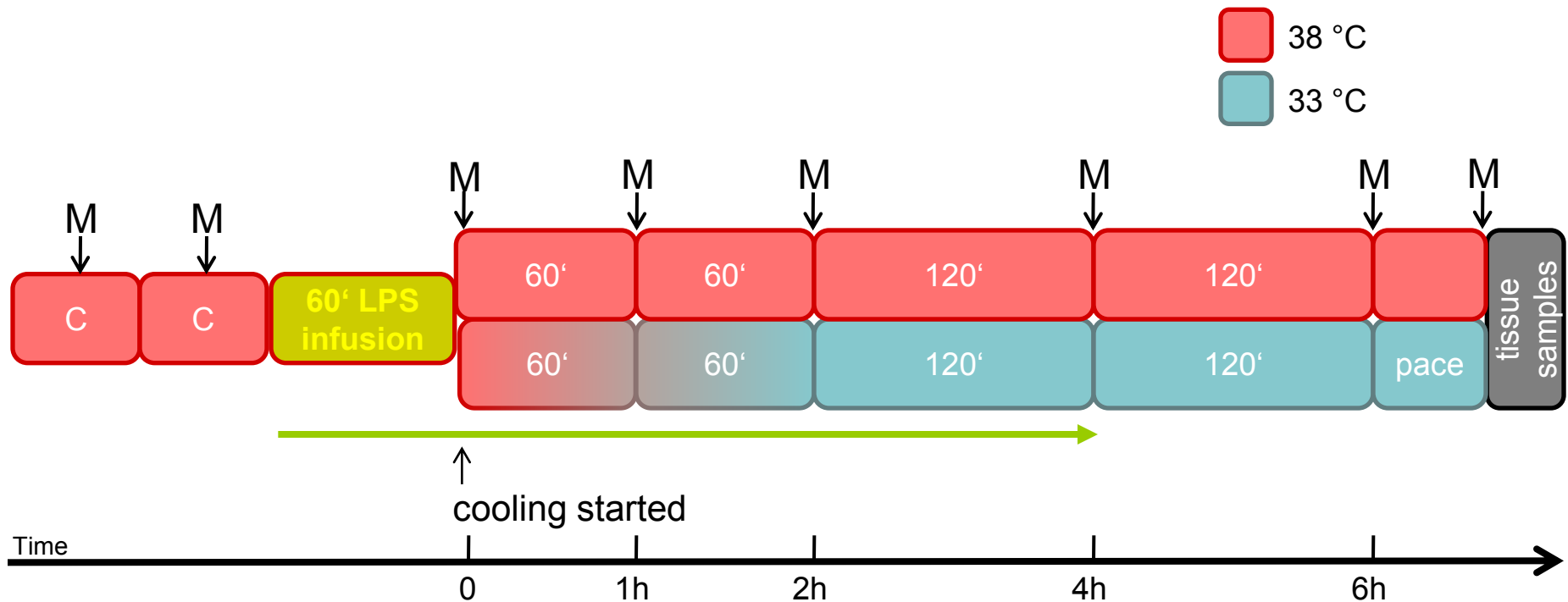

LPS: lipopolysaccharide, inductor of sepsis

M: saline, CO, BGA art./ven., blood samples, aortic occlusion

MH and LPS/sepsis: improved oxygen supply-demand balance



Medizinische Universität Graz

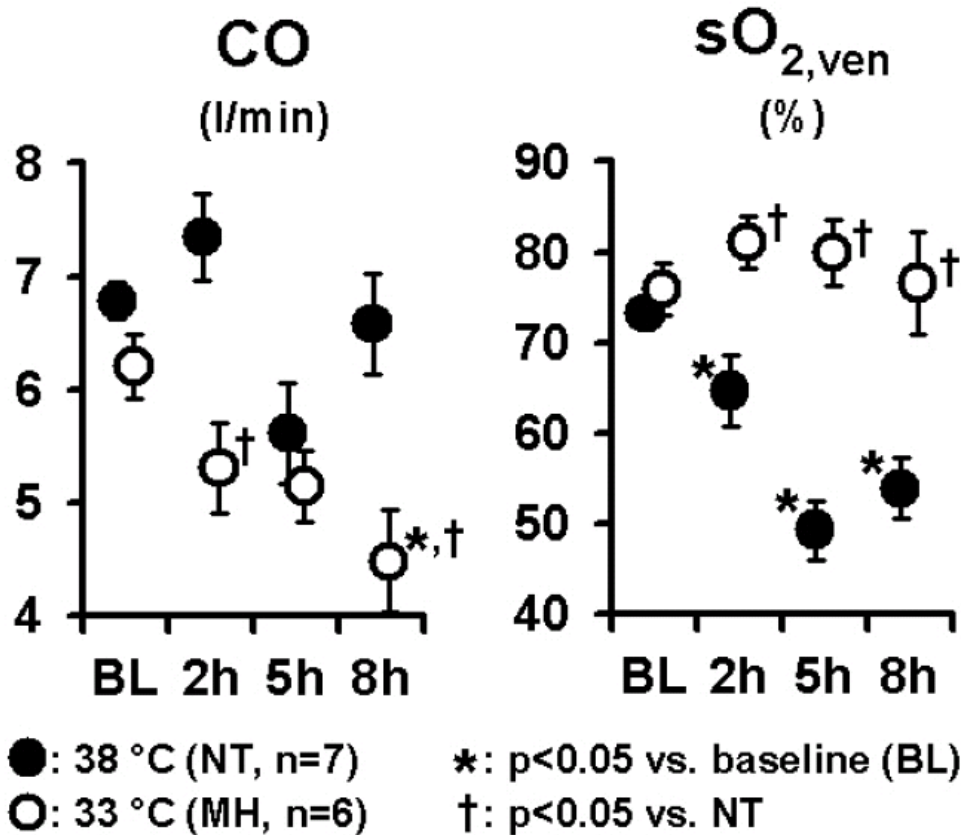

MH and LPS/sepsis: preserved pulmonary function

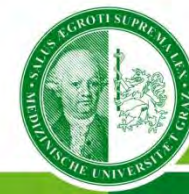

Medizinische Universität Graz

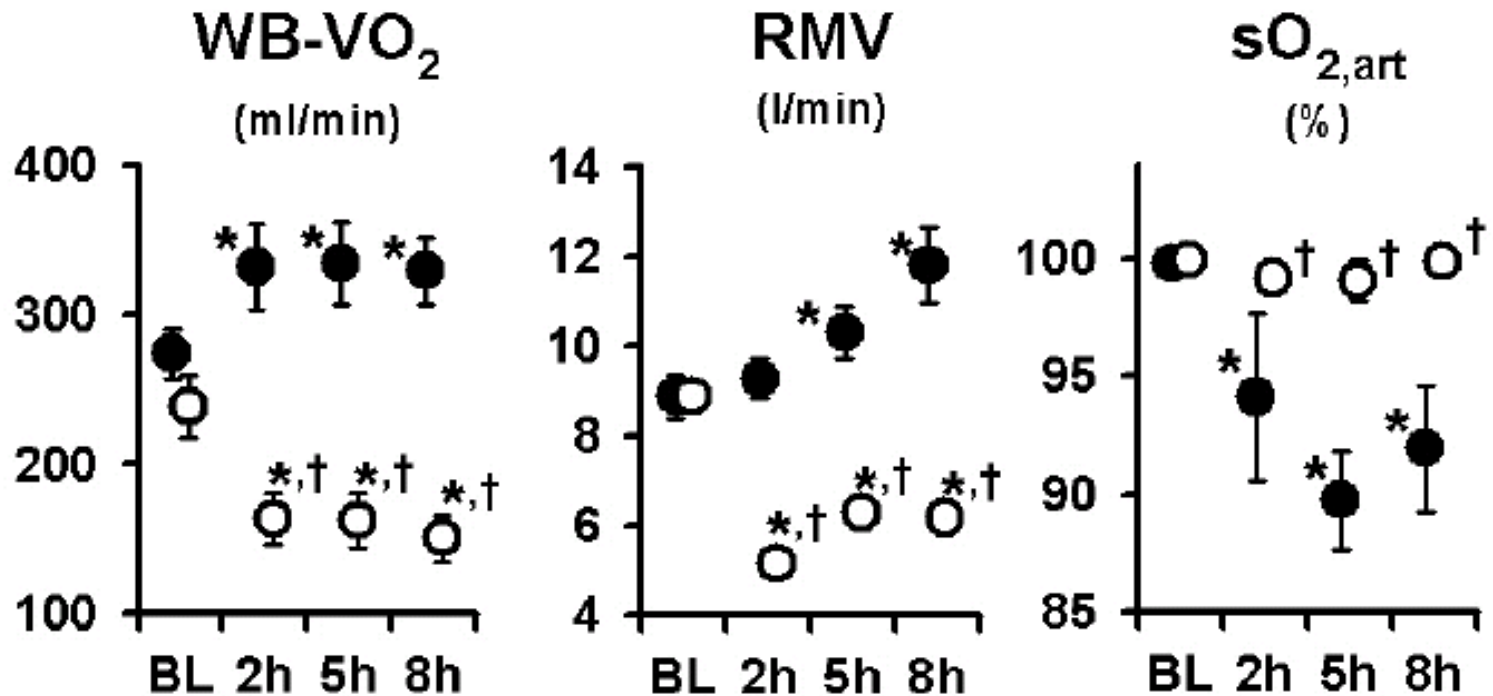

MH and LPS/sepsis: decreased symp. activation, preserved myocardial β -response

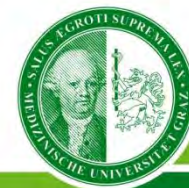

Medizinische Universität Graz

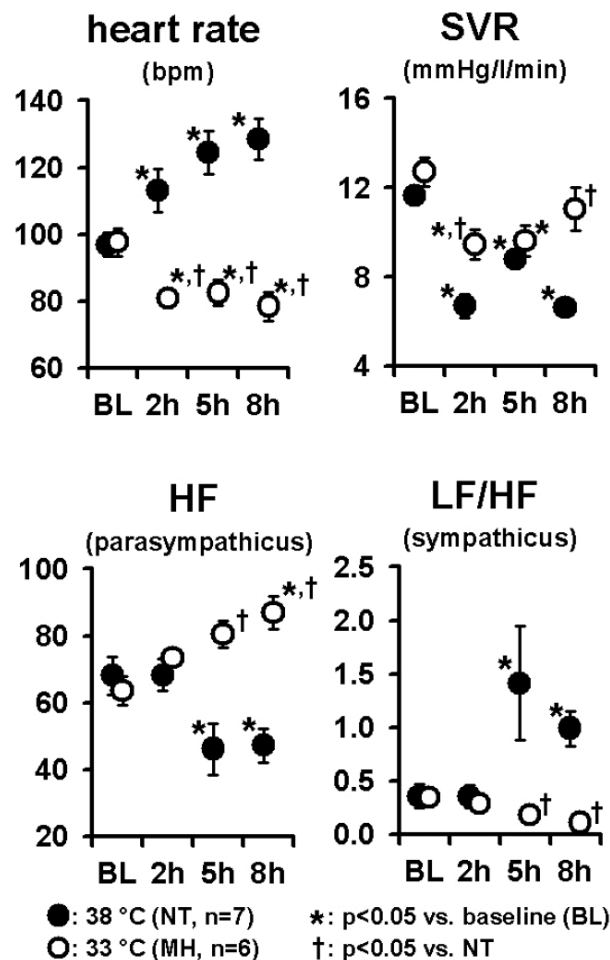

isolated muscle strips:

Developed force (%) in response to isoproterenol

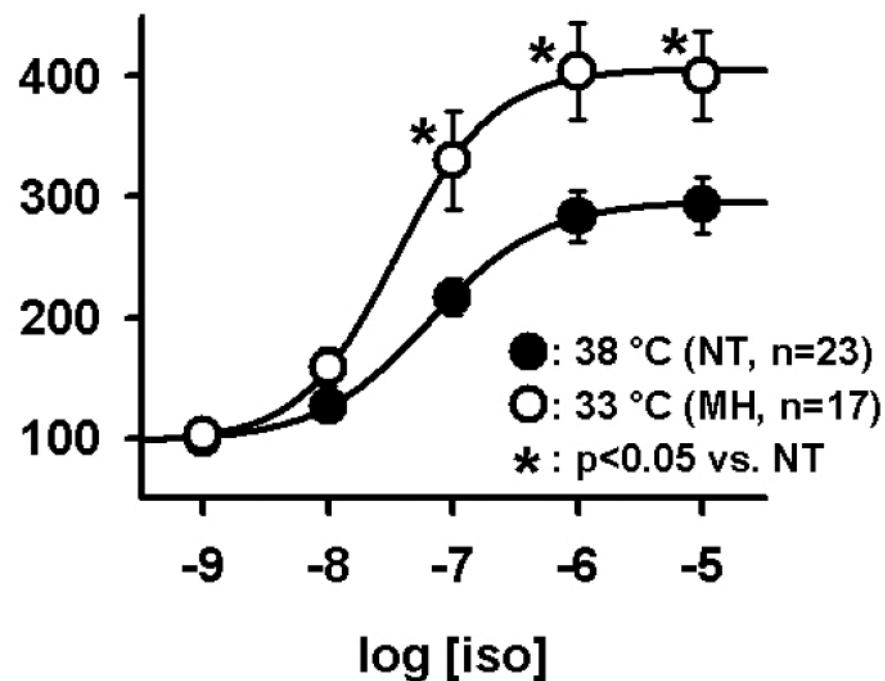



- reduces reperfusion injury
- positive inotrope
- decreases relaxation and distensibility, compensated by bradycardia
- improves systemic oxygen/supply balance, even at decreased cardiac output
- decreases sympathetic activation
- hypothesis: anti-inflammatory effects
- may evolve as a new therapy for
 - acute myocardial infarction
 - ICU: critical acute (but potentially transient) heart failure



Systolic (HFREF) vs diastolic (HFPEF) heart failure - Hemodynamics -

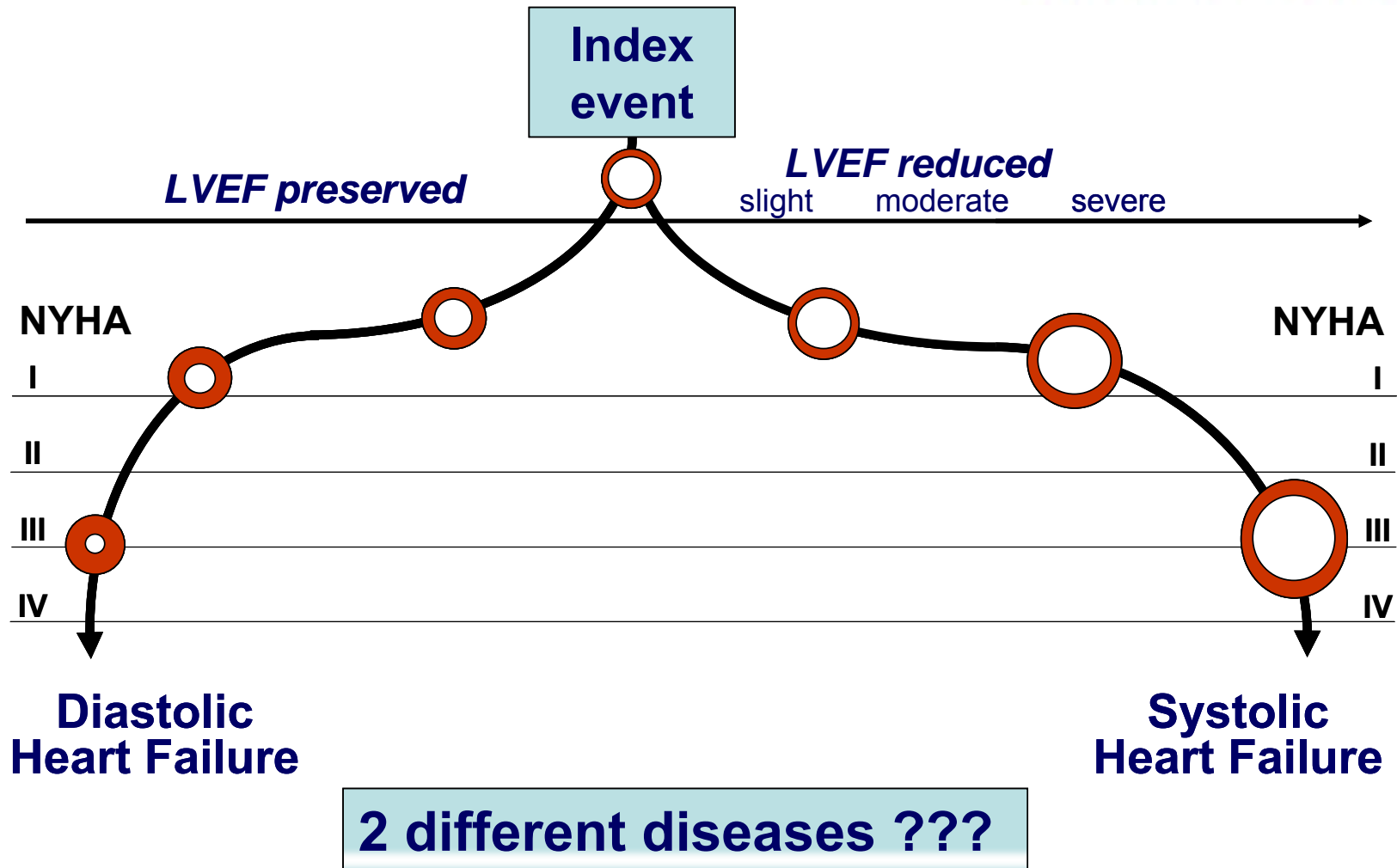

Modified after: G. De Keulenaer, 2006

healthy



HFPEF

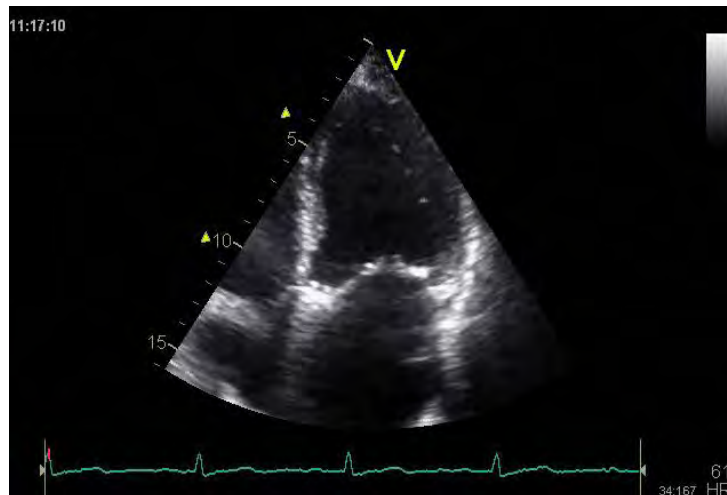

HFREF

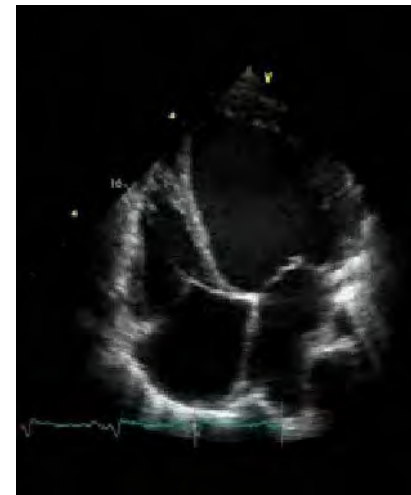

HFPEF vs HFREF

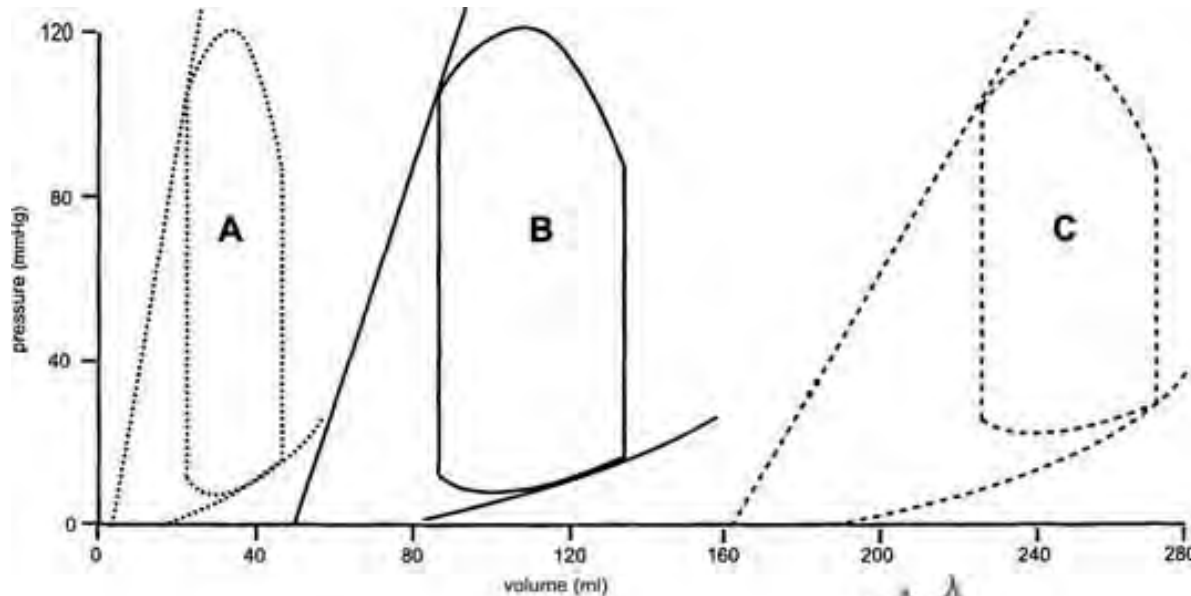

A. Concentric



B. Normal



C. Eccentric

- (aortic stenosis)
- risk factors
- no animal model
- no definite trigger
- no definite treatment!

- infarction
- tachycardia
- aortic stenosis
- toxic
- shunt

Remodeling in HFREF



Medizinische Universität Graz

Acute MI

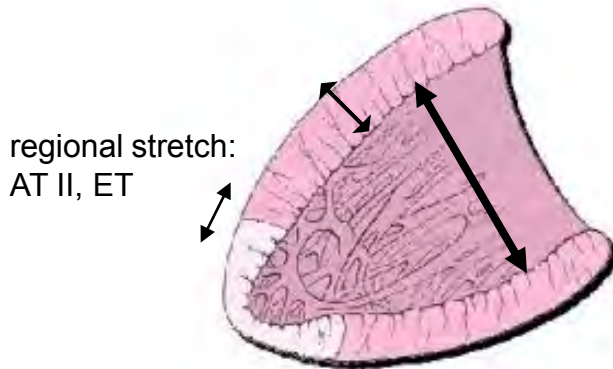

regional stretch:
AT II, ET

Extension

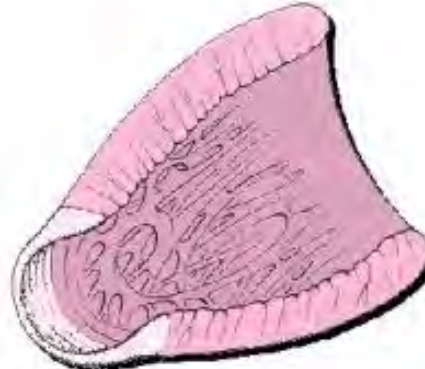

Dilatation

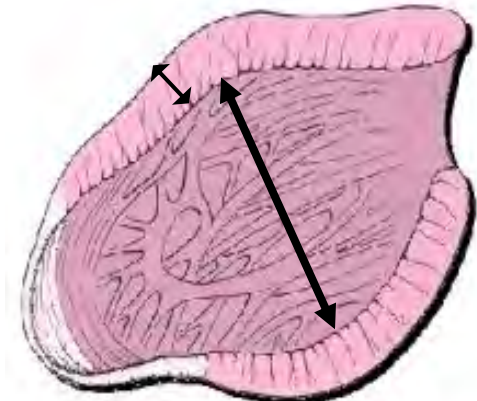

wall tension:
LaPlace

$$\frac{\text{pressure} * \text{radius}}{2 * \text{wall thickness}}$$

- diameter ↑
- wall thickness ↓
- ejection fraction ↓
- wall tension ↑↑

increased wall tension: - increased energy demand
- permanent maladaptive stimulus

Wall stress in HFPEF vs HFREF



Medizinische Universität Graz

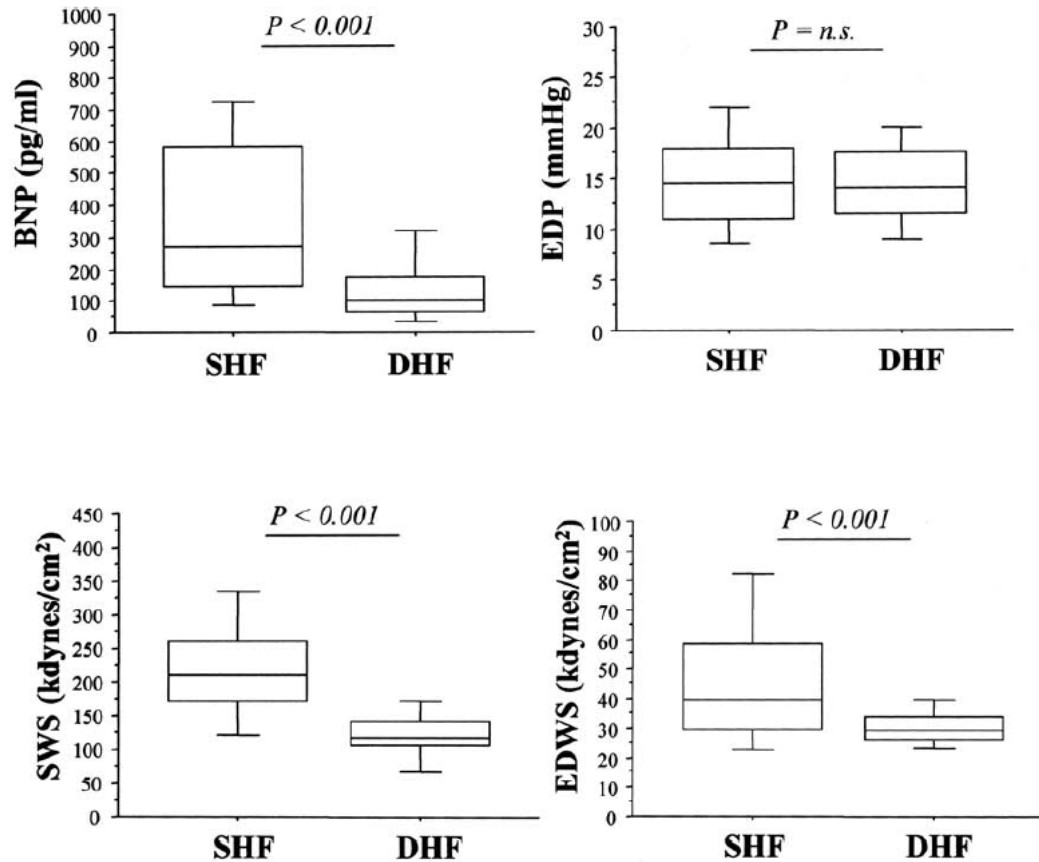

Iwanaga, JACC 2006

HFPEF: not only a LV disease



Medizinische Universität Graz



Systolic Dysfunction

Diastolic Dysfunction

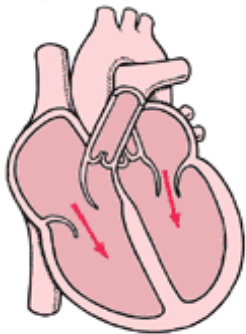

The enlarged ventricles fill with blood.

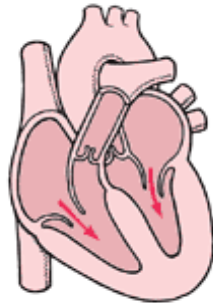

The stiff ventricles fill with less blood than normal.

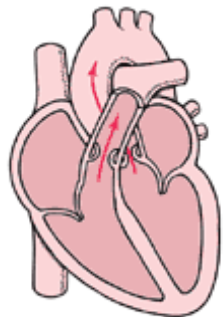

The ventricles pump out less than 40 to 50% of the blood.

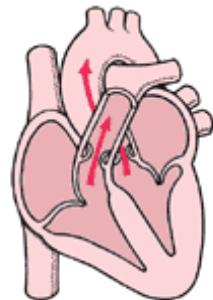

The ventricles pump out about 60% of the blood, but the amount may be lower than normal.

pulmonary hypertension

chronotropic incompetence

left atrial dysfunction

left ventricle:
- relaxation
- stiffness
- torsion

VA
coupling

arterial stiffening

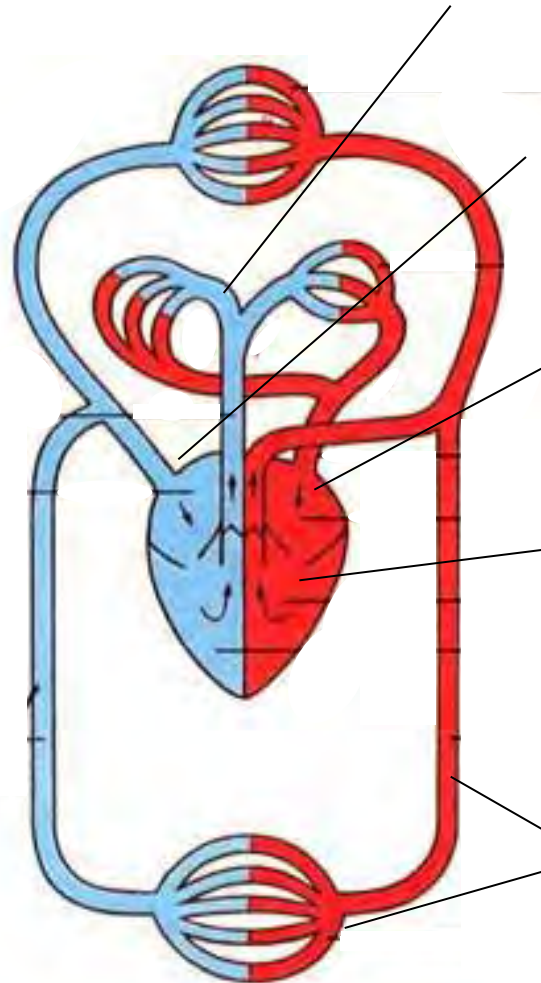

Pressure-volume analysis in HFPEF: patients



Control

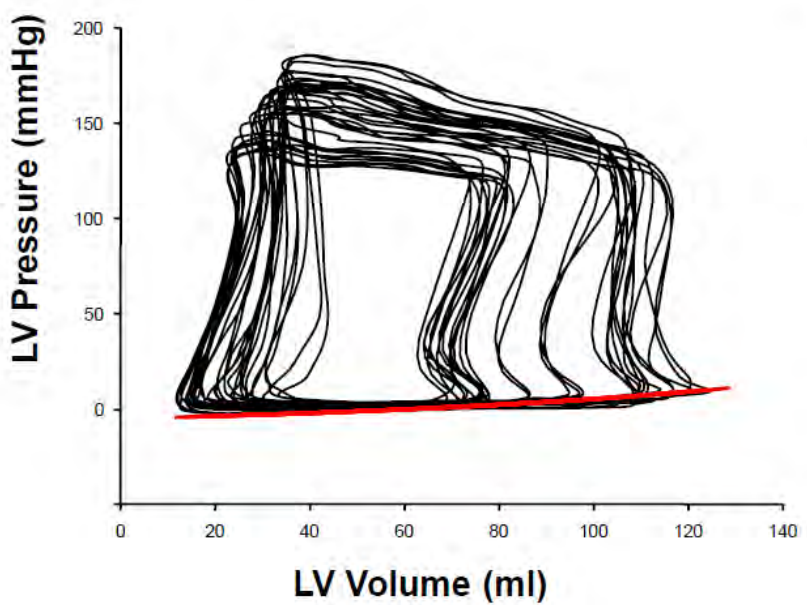

HFNEF

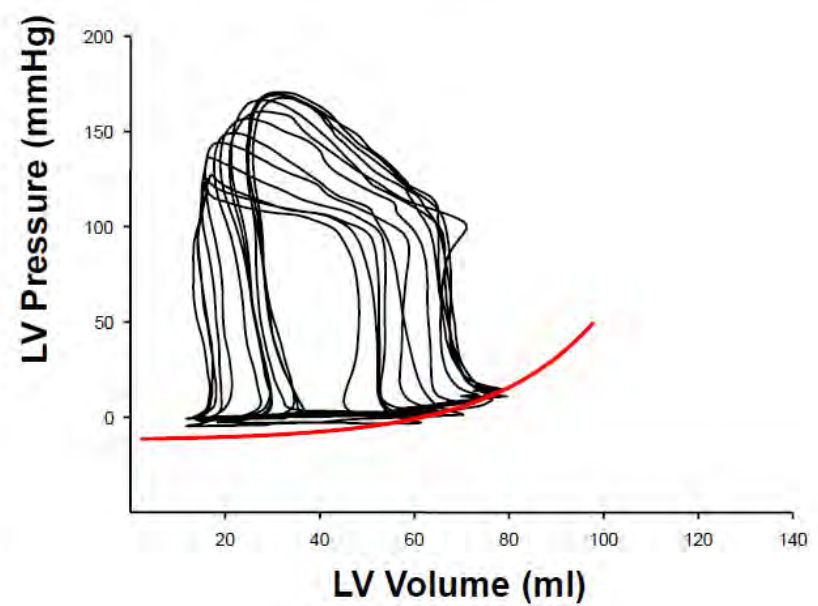

Pressure-volume analysis in HFPEF



leftward shift of EDPVR

slowed LV relaxation

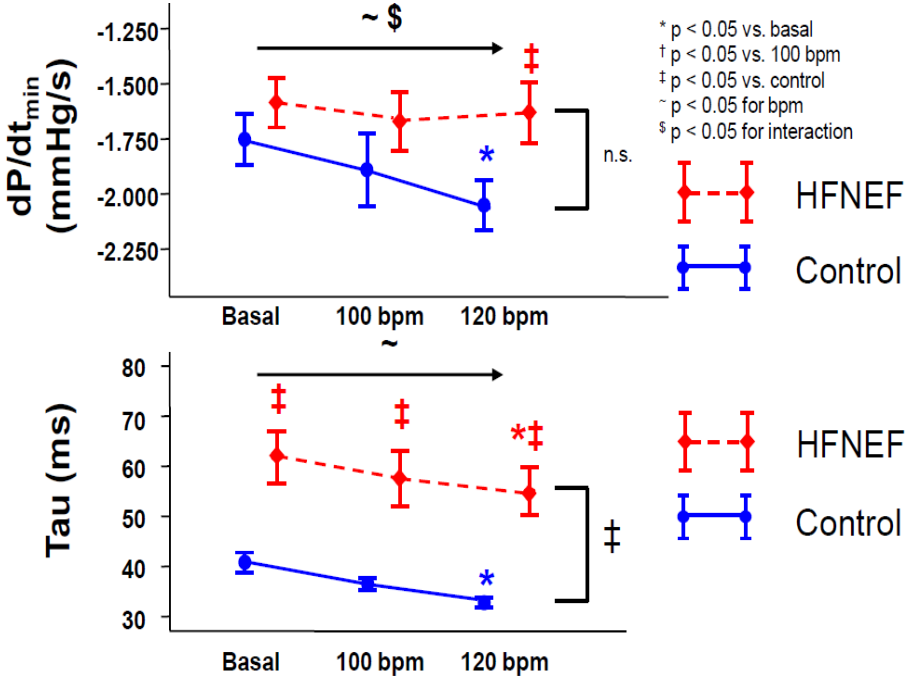
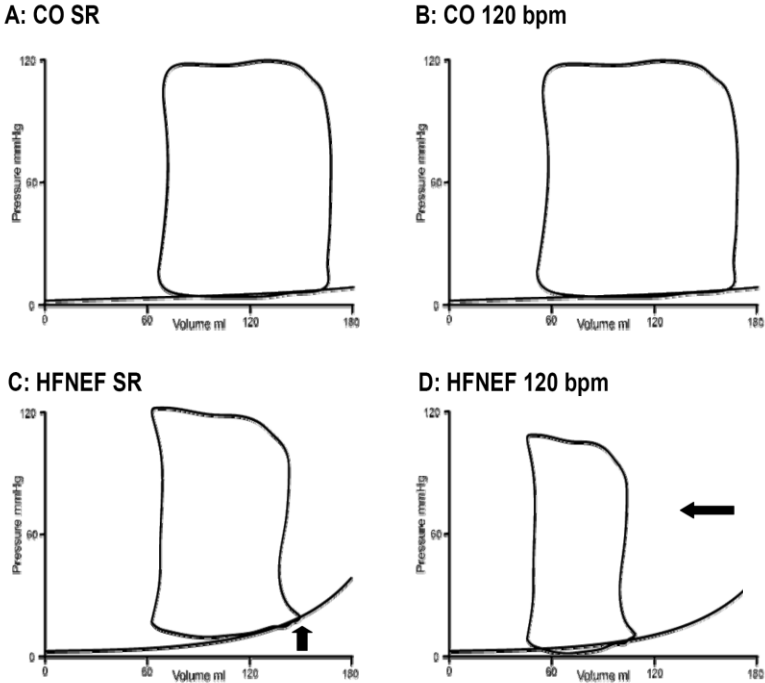

Westermann et al., Circ 2008; Wachter et al., EHJ 2009

Ventricular-arterial coupling in HFREF

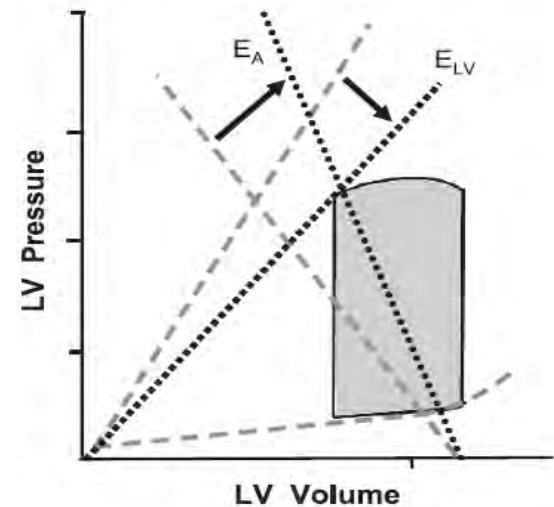
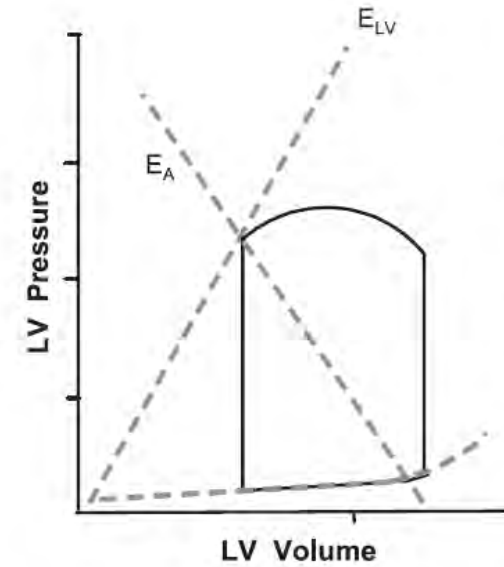
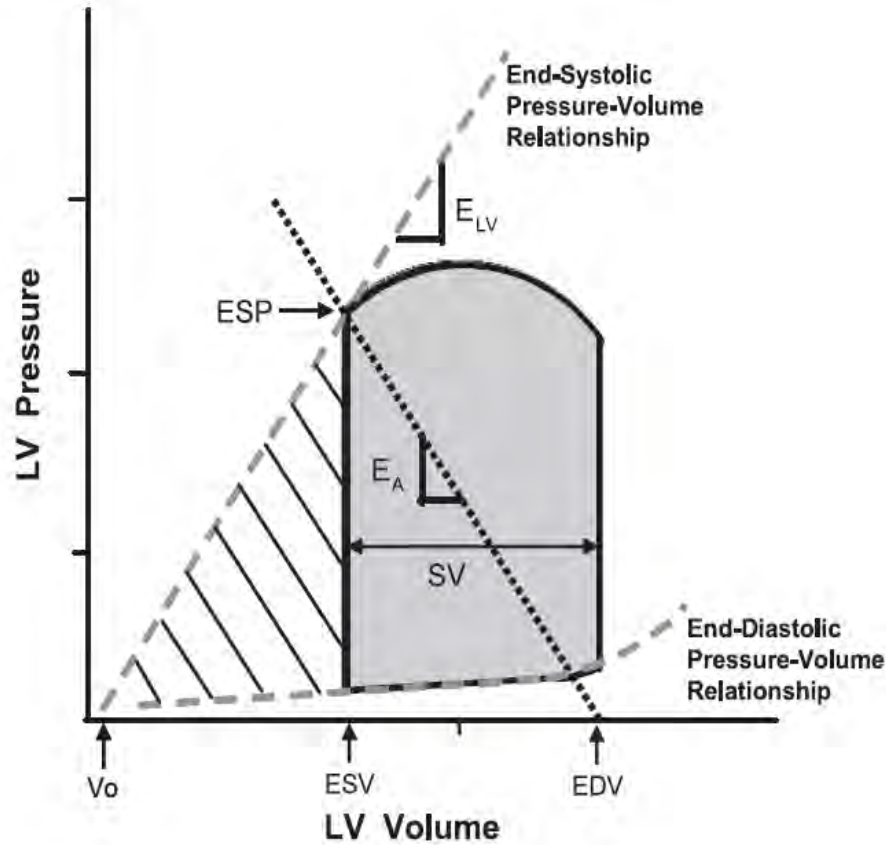

- | | |
|----------|---|
| E_{es} | ↓ |
| E_A | ↑ |
| EDV | ↑ |

Ventricular-arterial coupling in HFPEF



Medizinische Universität Graz

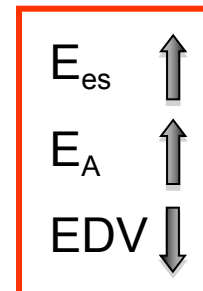
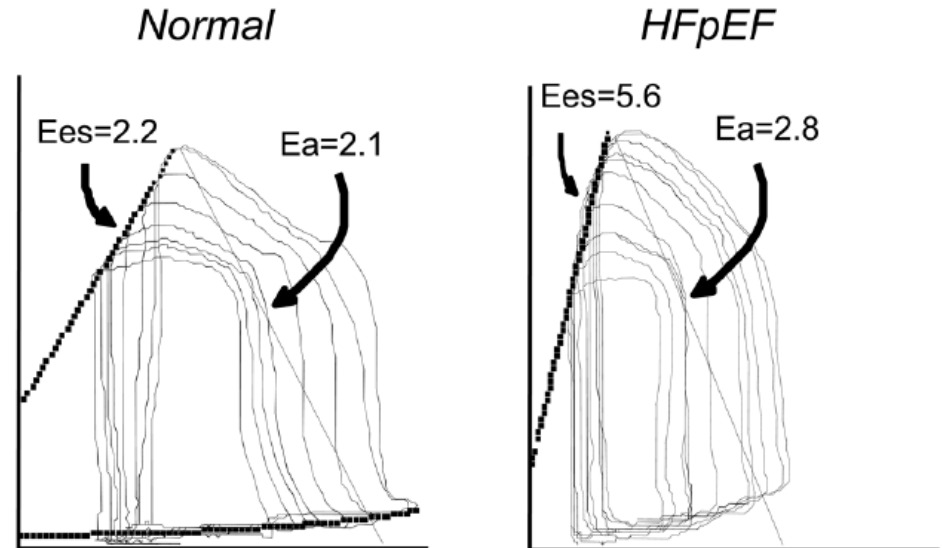
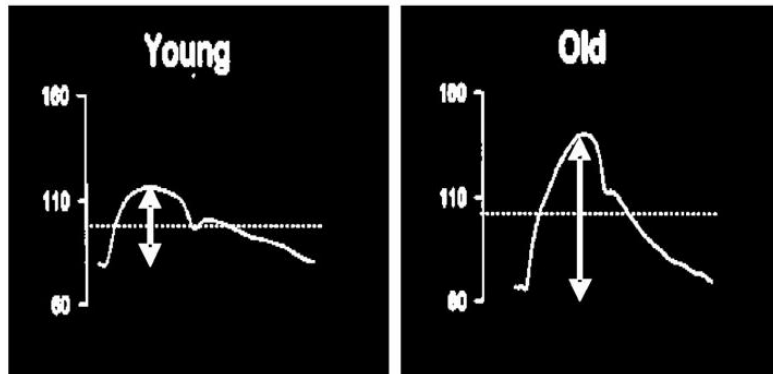
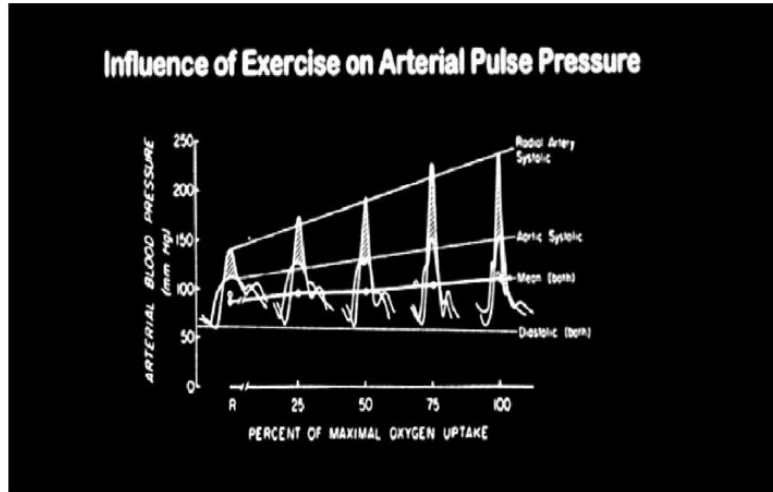

Borlaug et al., Heart Fail Clin 2008

PV-loops in HFPEF: exercise



Medizinische Universität Graz

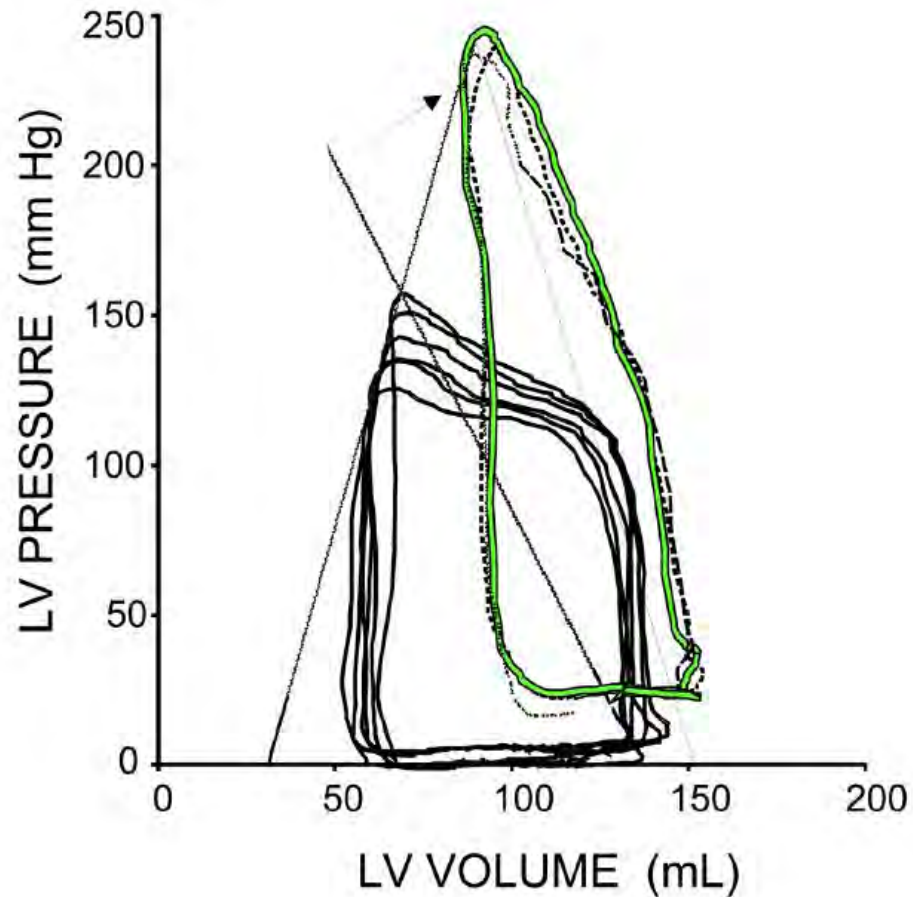

$E_{es} =$
 $E_A \uparrow$
 $EDV =$

Kawaguchi et al., Circ 2003

Aortic distensibility determines exercise capacity



Medizinische Universität Graz

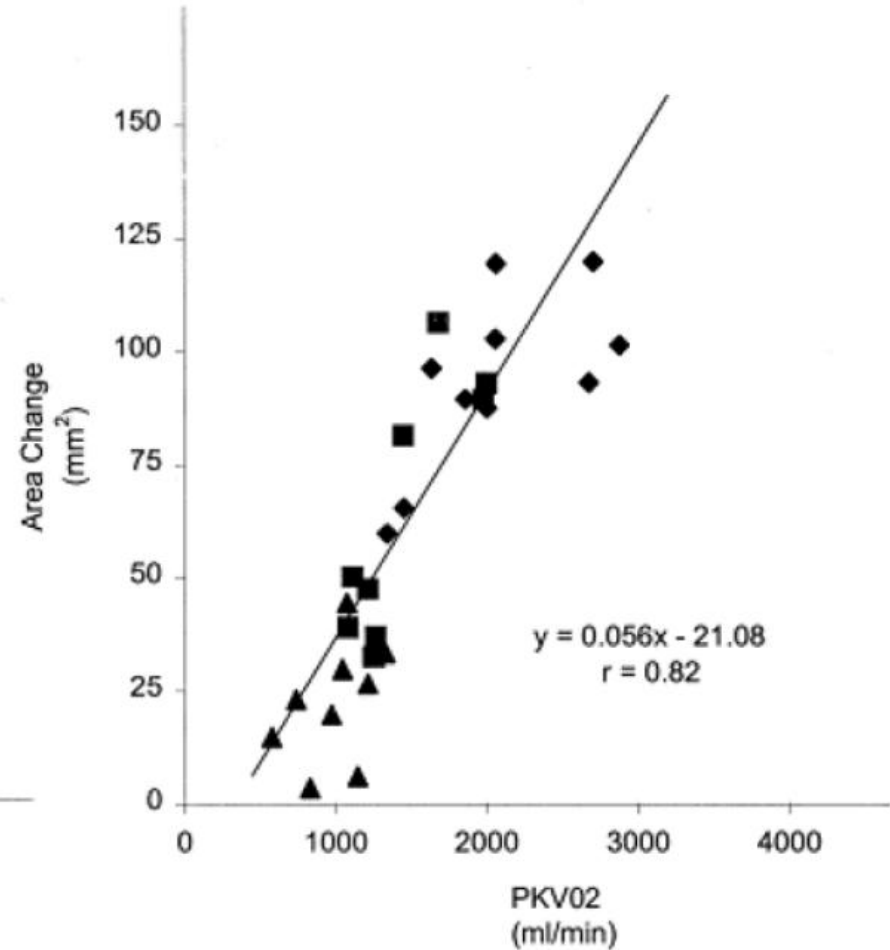
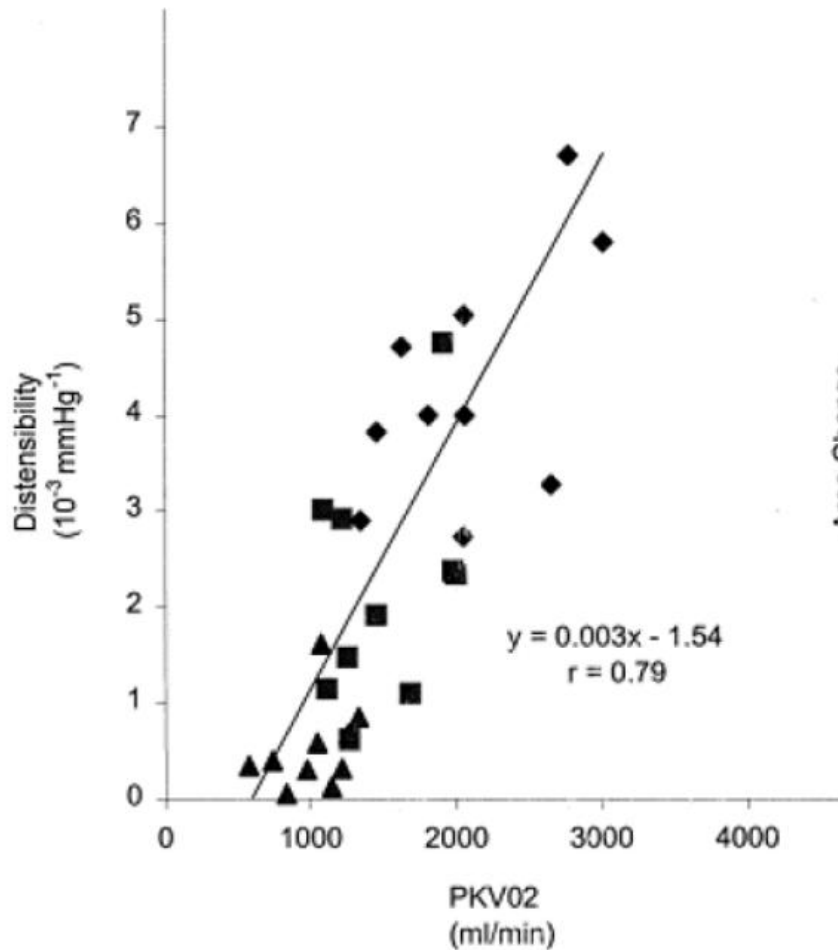

Hundley et al., JACC 2001

HFREF, RR 100/60 mmHg : give a lot vasodilatator: SNP 7 $\mu\text{g}/\text{kg}/\text{min}$



Medizinische Universität Graz

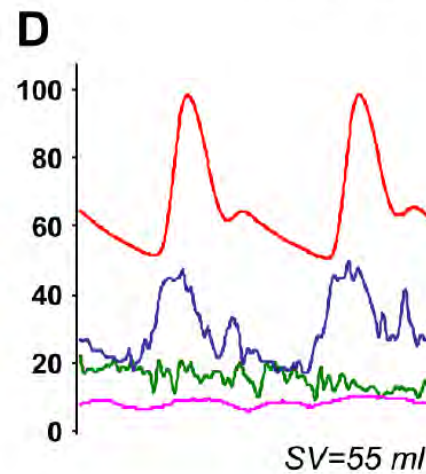
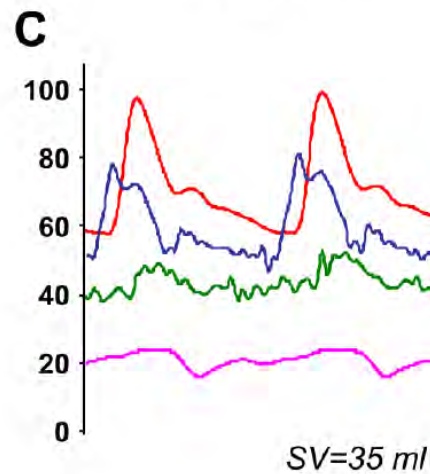
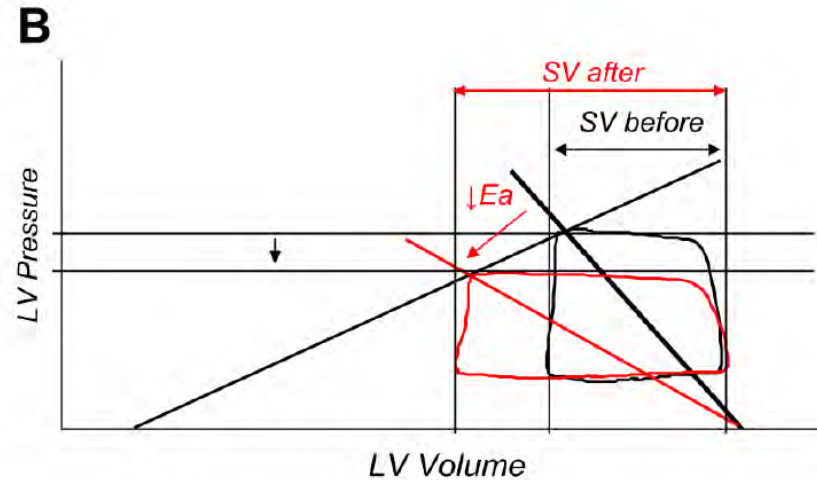
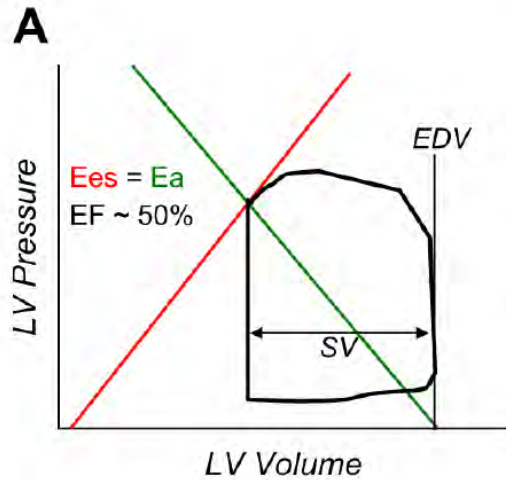

radial artery
pressure

pulm. pressure

wedge pressure

RA pressure

Borlaug et al., Heart Fail Clin 2009

HFPEF, RR 230/90 mmHg give a little vasodilator: SNP 2 $\mu\text{g}/\text{kg}/\text{min}$

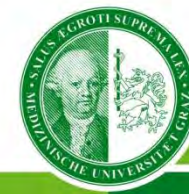

Medizinische Universität Graz

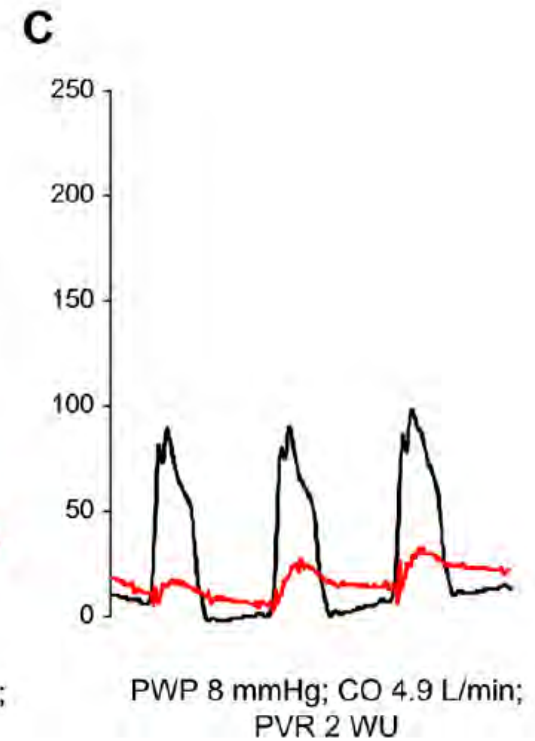
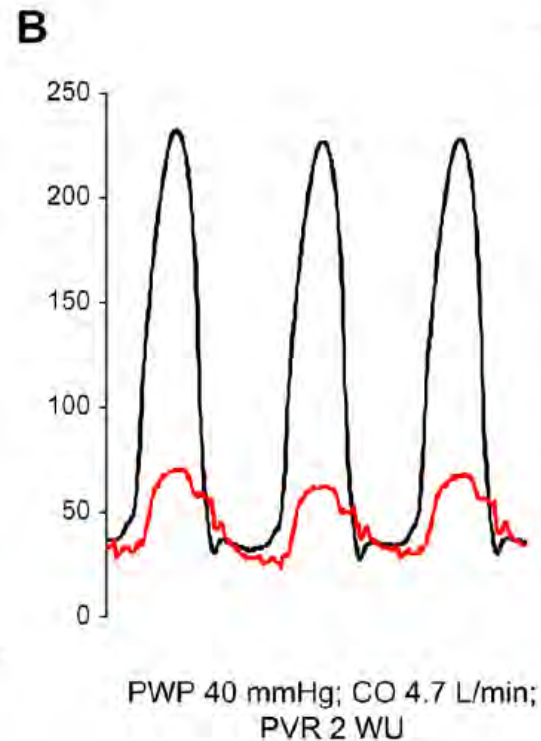
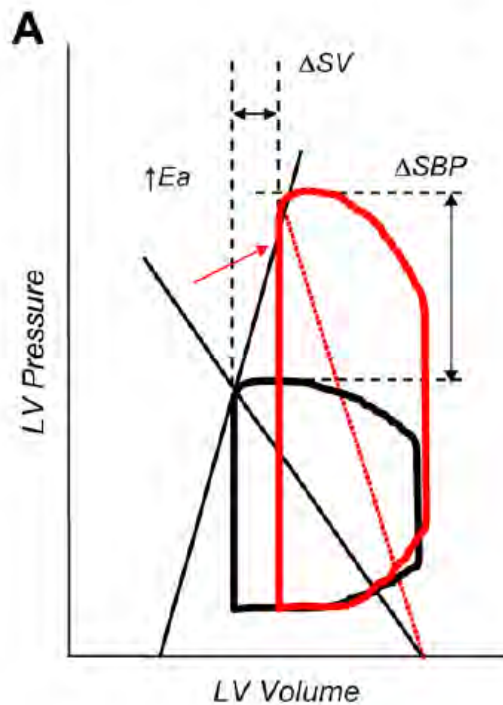

Borlaug et al., Heart Fail Clin 2009

Atrial function: HFPEF

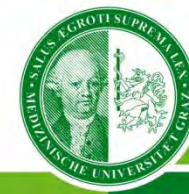

Medizinische Universität Graz

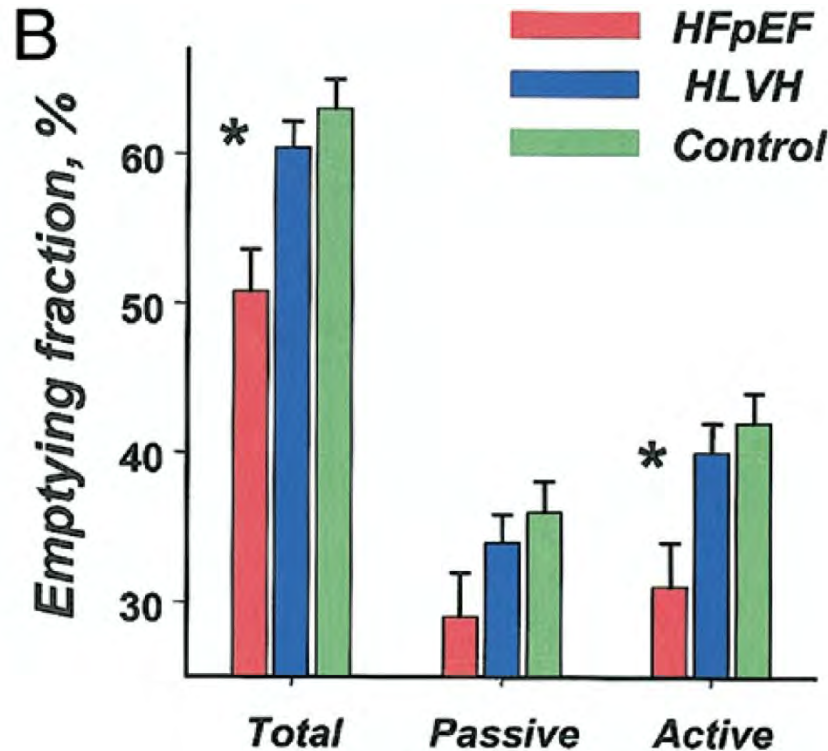

Annular A' velocity response to handgrip

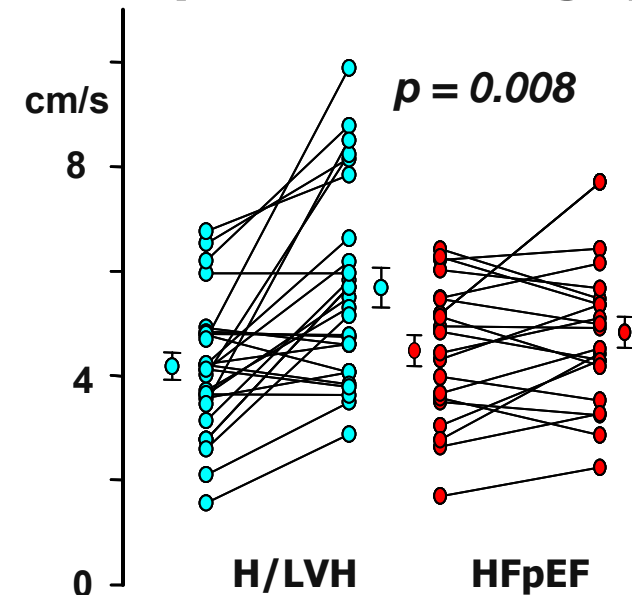

■ Reduced left atrial active emptying (LA EF) in HFpEF

■ Patients with HFpEF have decreased LA contractile reserve during stress

Melenovsky V, JACC 2007; 49: 198-207

Chronotropic incompetence



Medizinische Universität Graz

HFpEF (n=17) and matched controls (n=19): maximal effort upright cycle ergometry & radionuclide-ventriculography

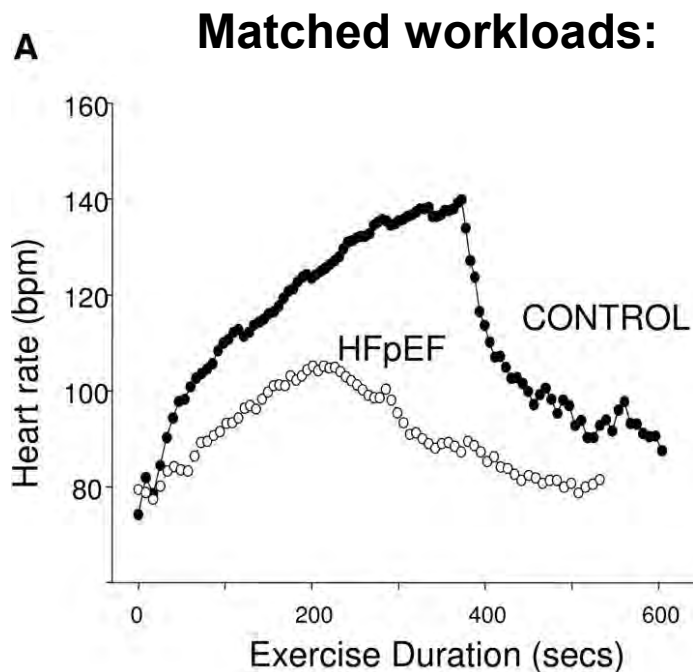

Reduced chronotropic, vasodilator, and cardiac output reserve during exercise

B Heart Rate Acceleration

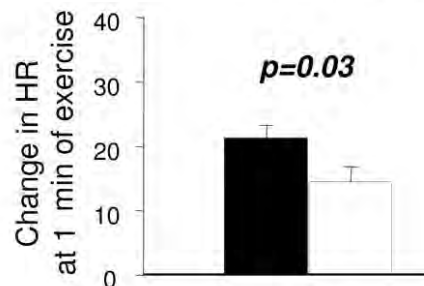
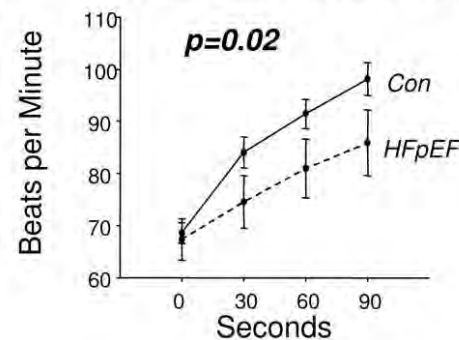

Heart Rate Deceleration

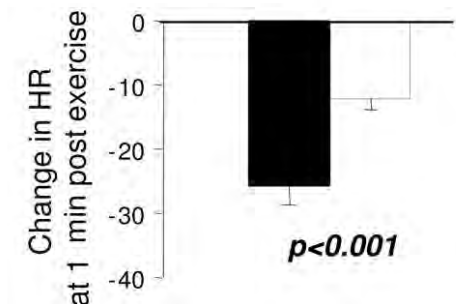
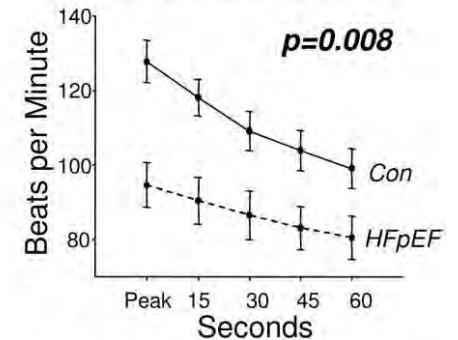

Borlaug et al., Circulation 2006; 114(20)

Pulmonary hypertension



Medizinische Universität Graz

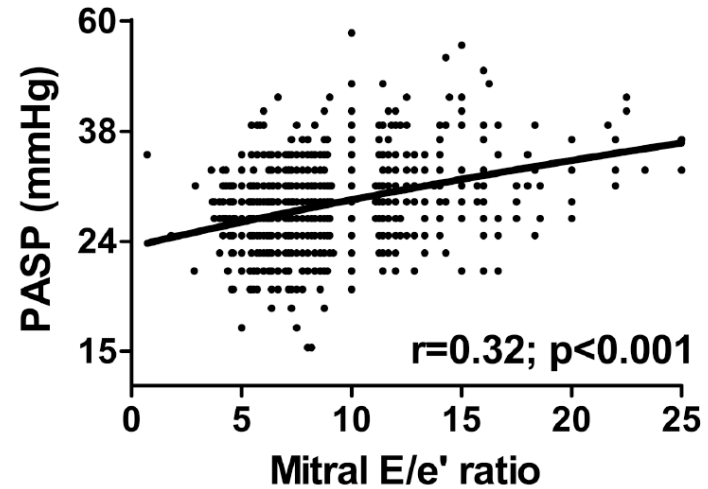
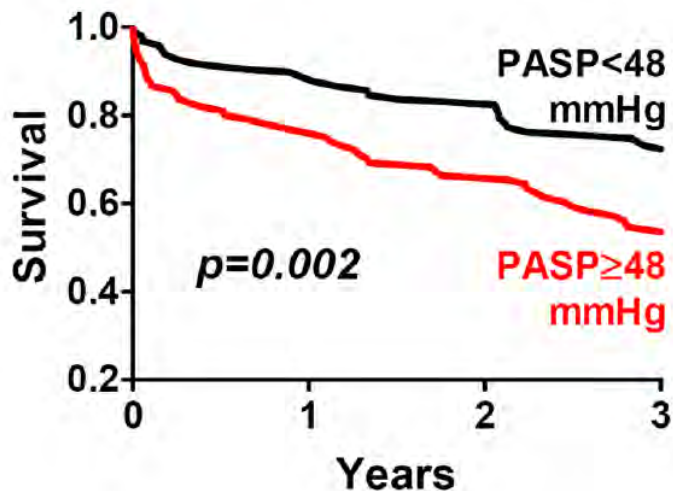
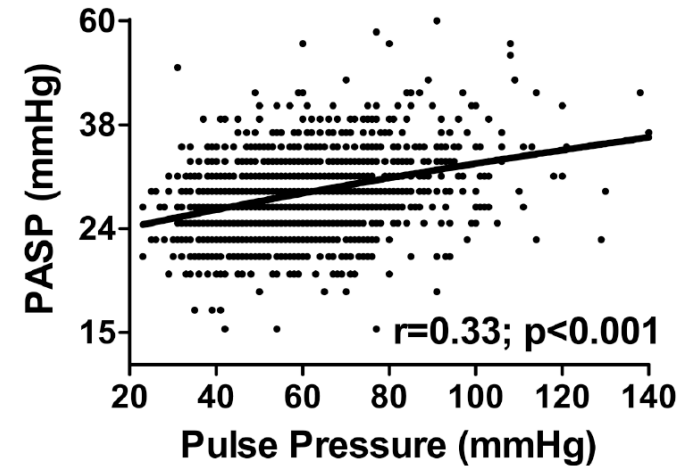
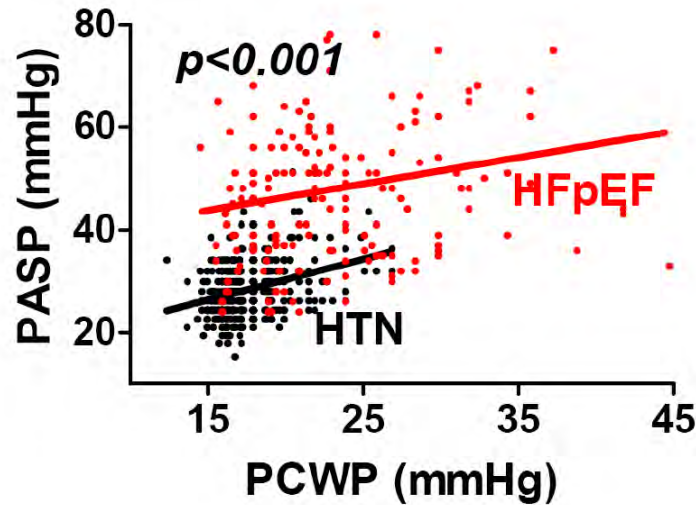

Lam et al., JACC 2009

Lam et al., Circ 2009

The contracts like a towel

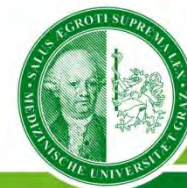

Medizinische Universität Graz

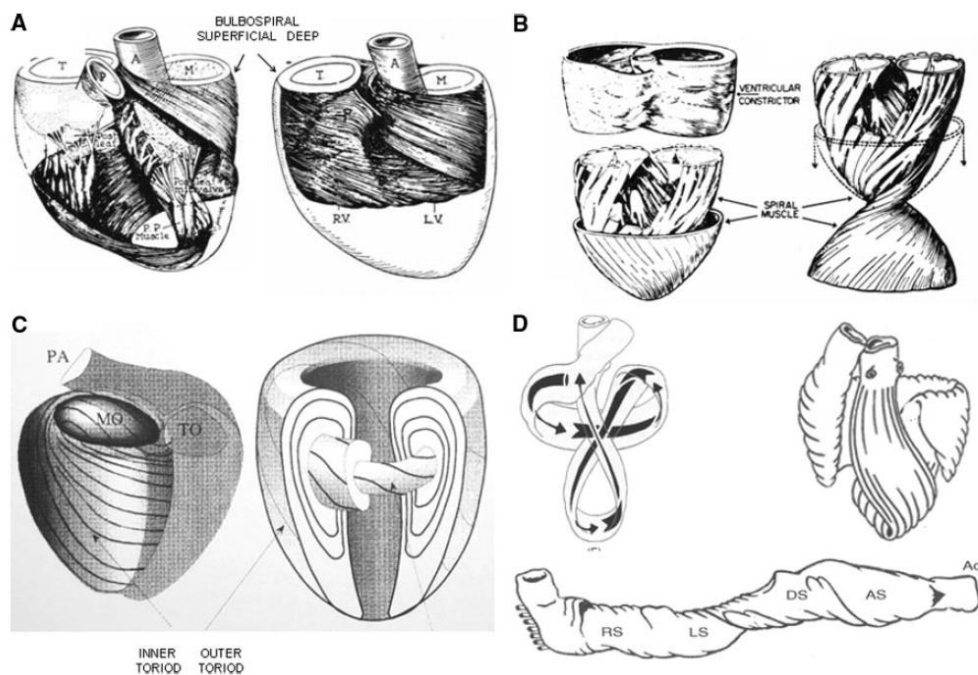

Buckberg, Circulation 2008

Rotation and twist



Medizinische Universität Graz

Control

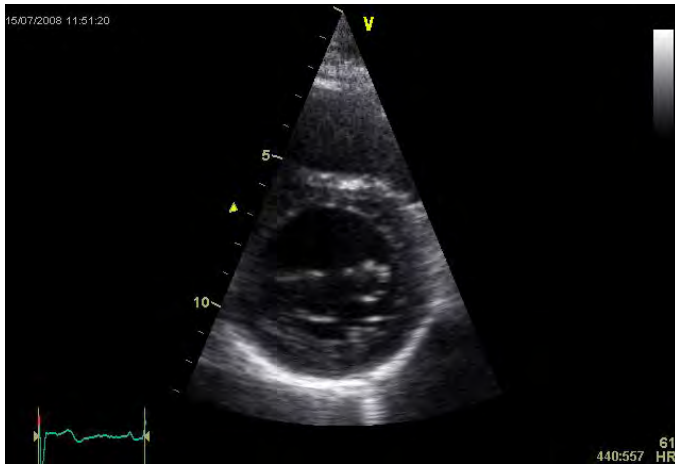

HFPEF

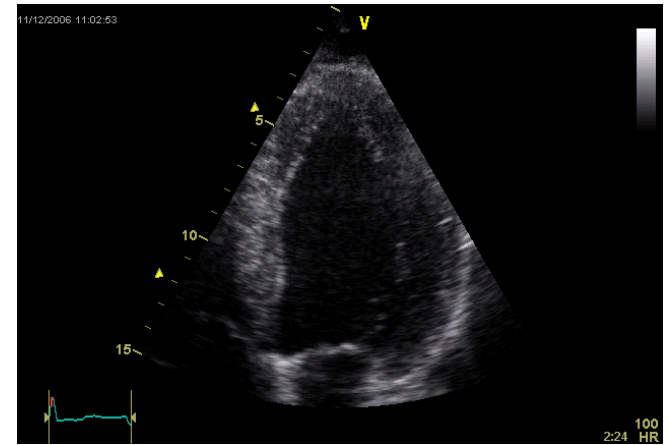

Control

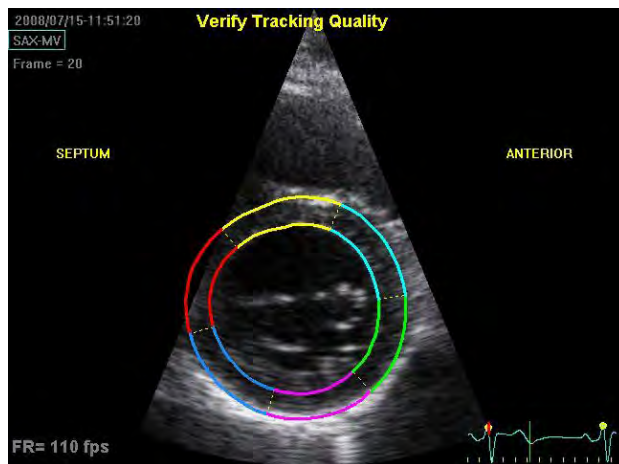

HFPEF

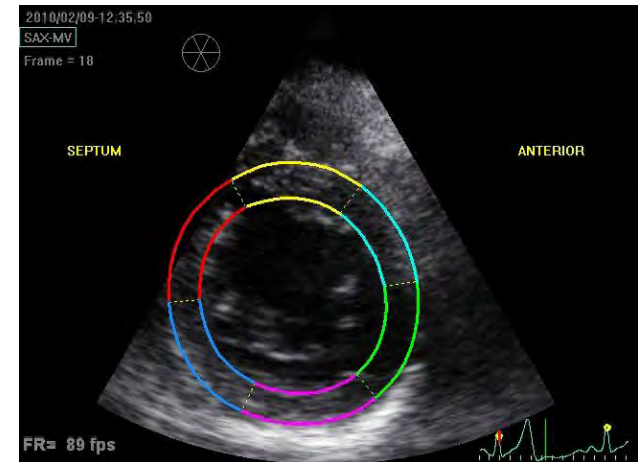

Rotation is decreased in HFPEF



Medizinische Universität Graz

Patient, ♂ 62 years



Control, ♀ 61 years

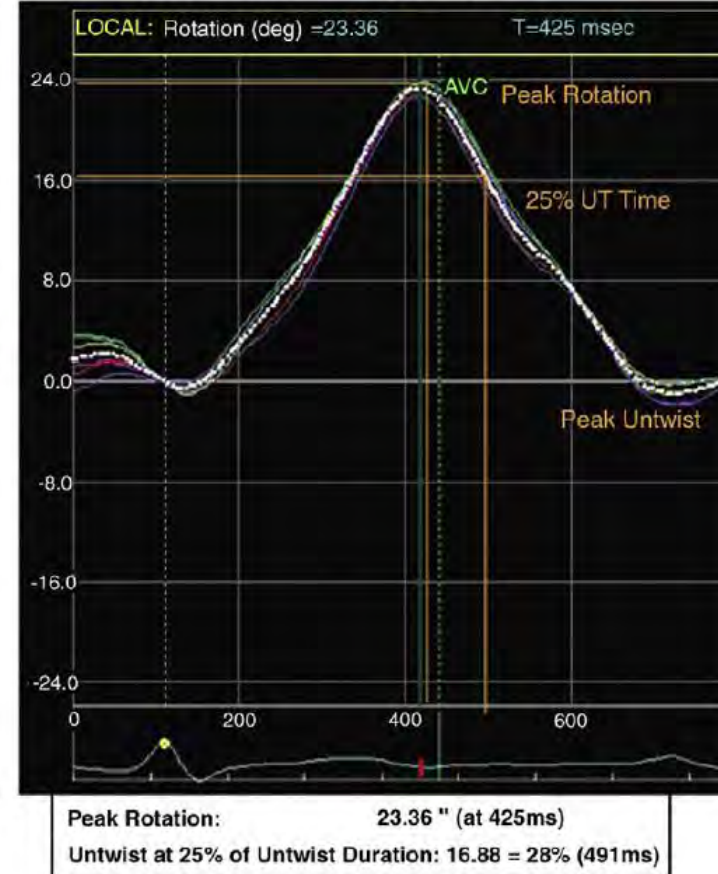

Tan et al., JACC 2009

Rotation in physiol. vs path. hypertrophy

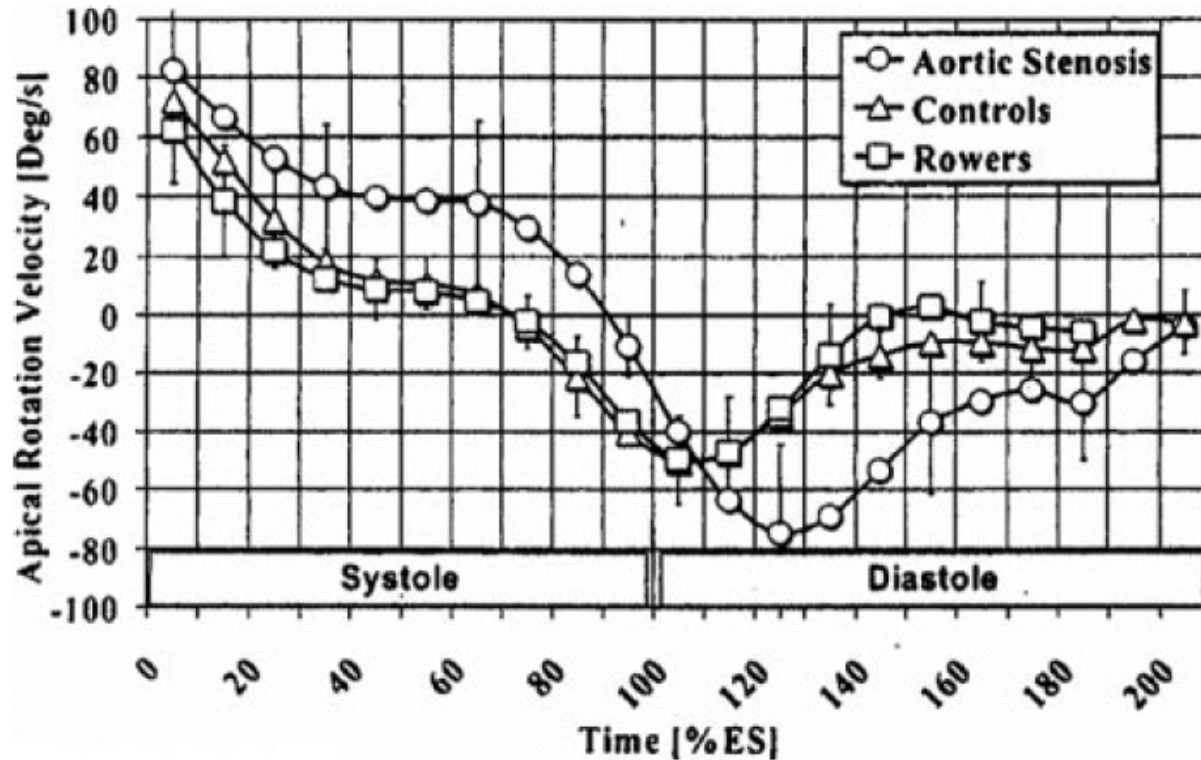

Pts. with AST, all LV EF > 50%

LV biopsies during surgery

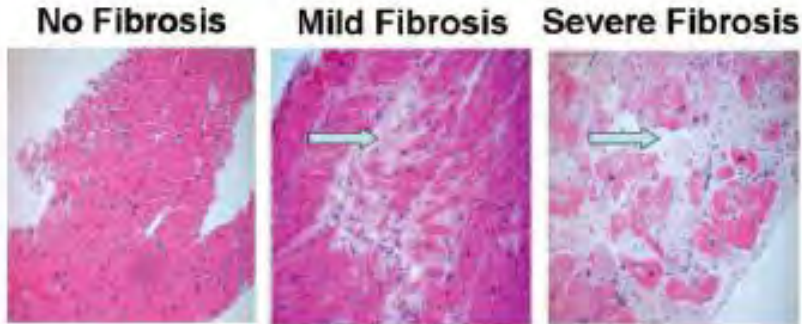
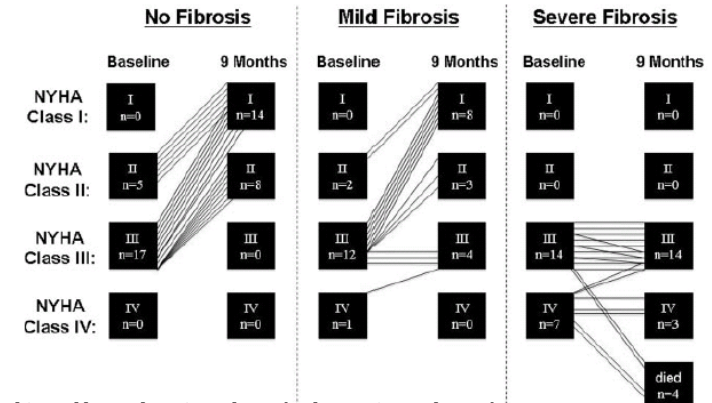
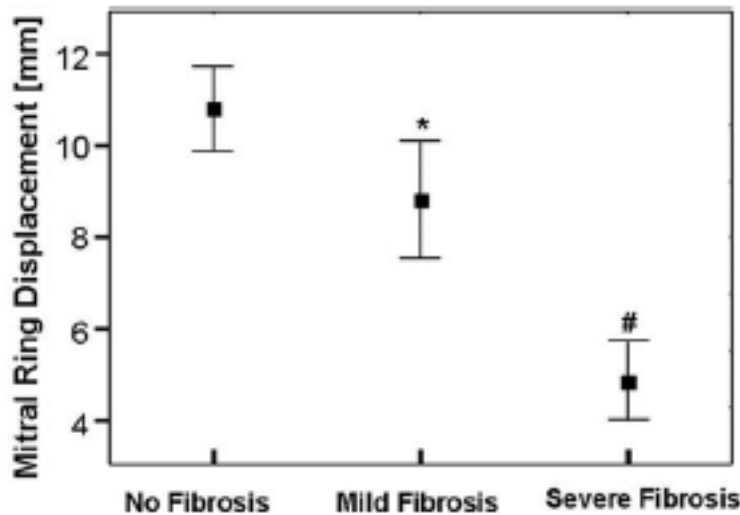

Table 2. Change in Radial and Longitudinal LV Function After AVR

	Baseline	10 Days	9 Months	P*	P†
No fibrosis					
Radial strain, %	31 (11)	44 (16)	55 (16)	0.001	<0.001
Radial strain rate, s ⁻¹	1.7 (0.4)	2.3 (0.6)	2.5 (0.5)	<0.001	<0.001
Longitudinal strain, %	-19 (5)	-19 (5)	-22 (5)	0.836	<0.001
Longitudinal strain rate, s ⁻¹	-1.2 (0.2)	-1.3 (0.4)	-1.5 (0.2)	0.142	0.008
Mild fibrosis					
Radial strain, %	29 (9)	41 (15)	40 (15)	0.004	0.003
Radial strain rate, s ⁻¹	1.7 (0.4)	2.3 (0.6)	2.3 (0.5)	0.004	0.006
Longitudinal strain, %	-15 (6)	-15 (4)	-18 (5)	0.852	0.021
Longitudinal strain rate, s ⁻¹	-0.9 (0.3)	-1.1 (0.3)	-1.3 (0.4)	0.157	0.009
Severe fibrosis					
Radial strain, %	26 (11)	31 (14)	34 (11)	0.492	0.021
Radial strain rate, s ⁻¹	1.6 (0.3)	1.6 (0.5)	1.7 (0.4)	0.843	0.245
Longitudinal strain, %	-10 (5)	-11 (6)	-14 (5)	0.853	0.079
Longitudinal strain rate, s ⁻¹	-0.6 (0.2)	-0.8 (0.3)	-0.8 (0.2)	0.044	0.040

Fibrosis = longitudinal function



Longitudinal strain (shortening):
 - negatively correlated with fibrosis
 - predicts recovery after aortic valve replacement

Disturbed LV relaxation in HFPEF: energetics



Medizinische Universität Graz

calcium transients: unknown!

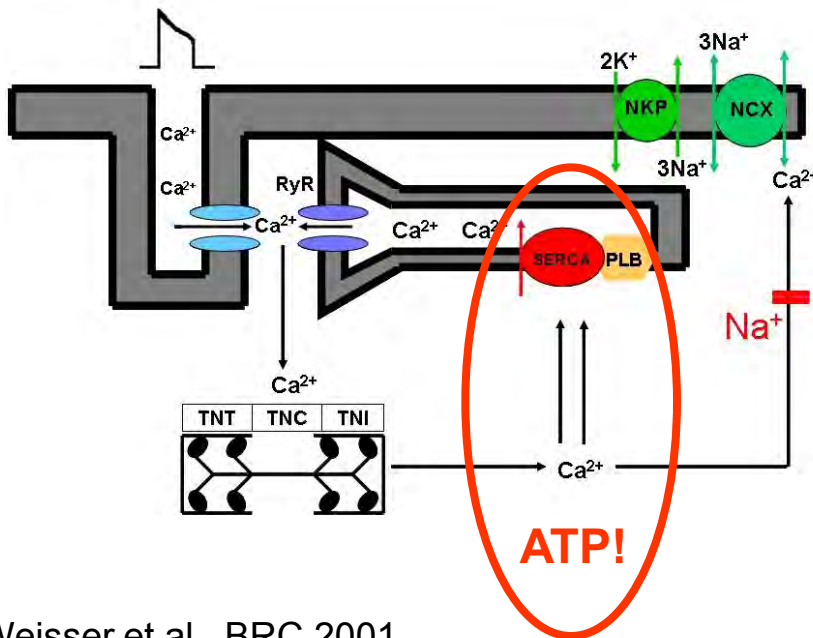
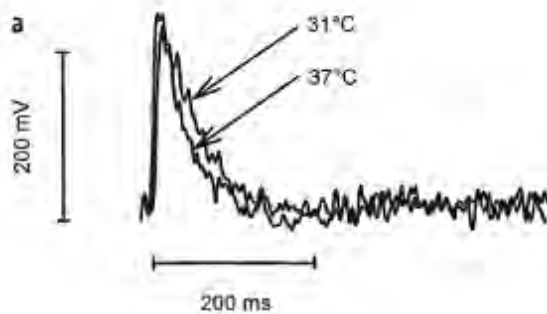

impaired myocardial energetics in DHF

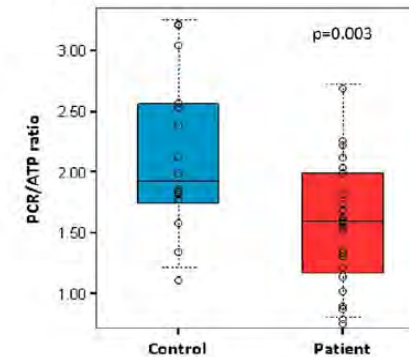

Variable	Patients With HFpEF (n = 37)	Control Subjects (n = 20)	p Value
Exercise HR, beats/min	97 ± 14	114 ± 11	<0.001
Exercise SBP, mm Hg	204 ± 26	198 ± 27	0.45
Exercise DBP, mm Hg	95 ± 15	97 ± 7	0.56
Exercise MABP, mm Hg	132 ± 15	131 ± 9	0.85
Ejection fraction, %			
Rest	65 ± 9	64 ± 9	0.61
Exercise	66 ± 9	72 ± 8	0.05
Time to peak filling, RR			
Rest	0.18 ± 0.08	0.18 ± 0.09	0.84
Exercise	0.25 ± 0.09	0.16 ± 0.08	0.001
Δ nTTPF	+0.07 ± 0.11	-0.03 ± 0.12	<0.005

Weisser et al., BRC 2001
Pieske et al., JMCC 2002

Disturbed LV relaxation in HFPEF: myofilaments



Medizinische Universität Graz

The titin spring : restoring forces and stiffness

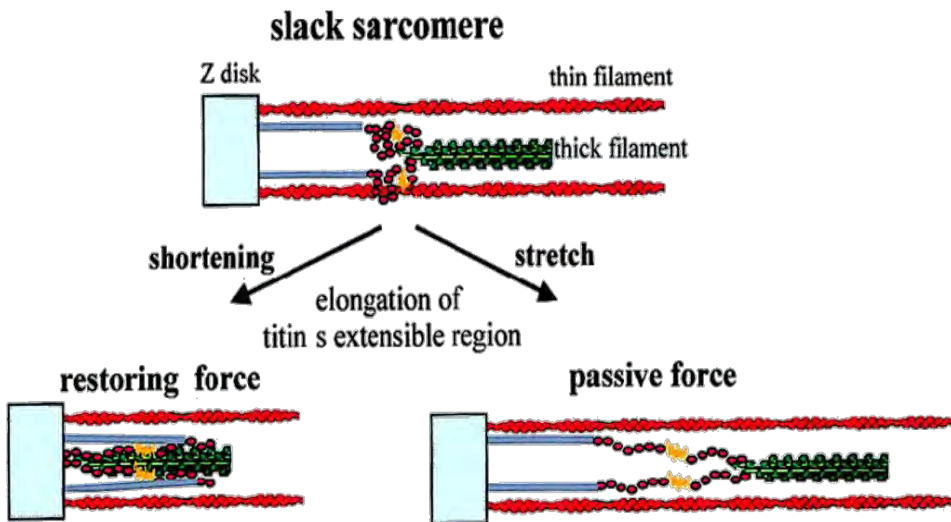

Bell et al., Circ Res 2000; 87:235-240

PKA or PKG mediated phosphorylation of N2B-unique sequence

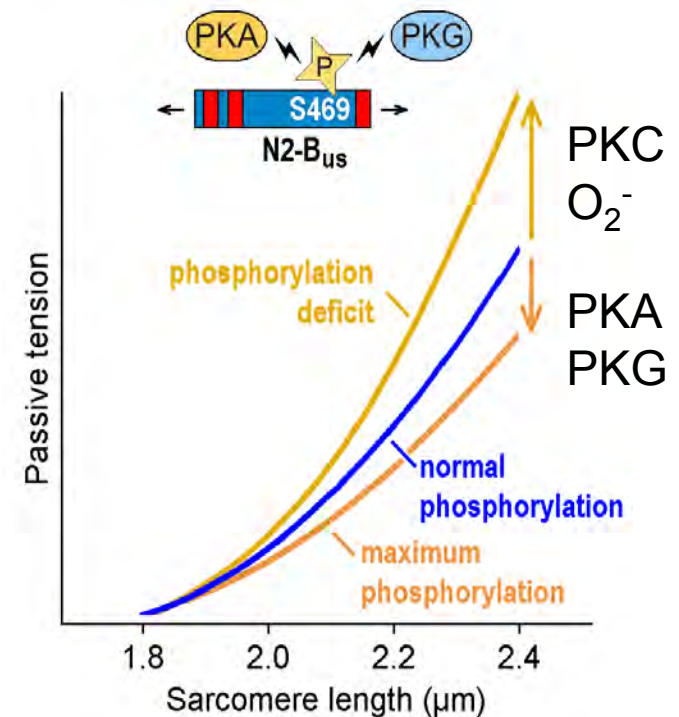

Hidalgo et al., Circ Res, 2009

10 days NOS inhibition in dogs mimicks a HFPEF phenotype



Medizinische Universität Graz

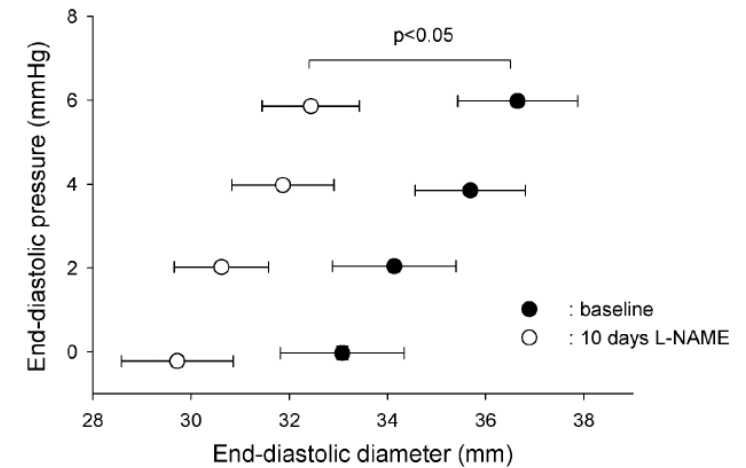
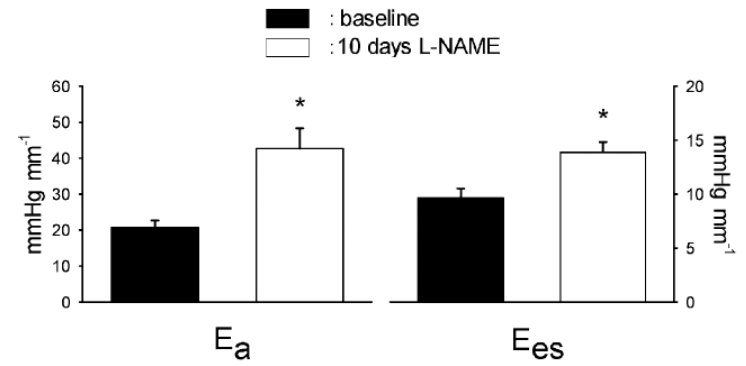
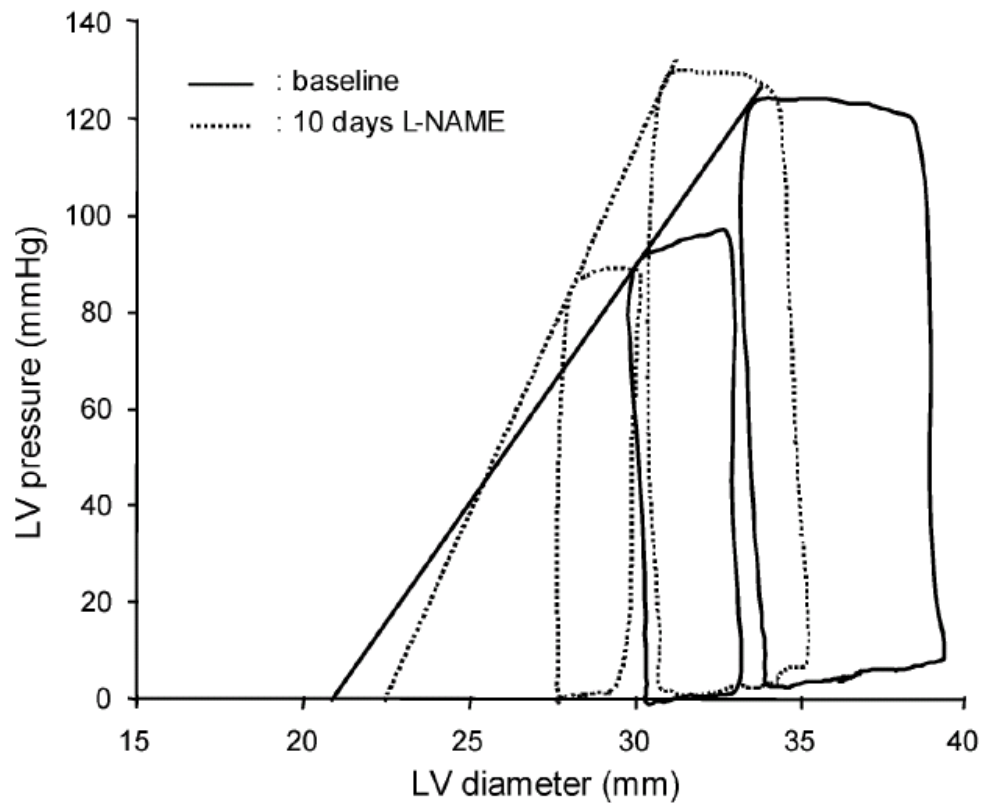

Post et al., J Physiol 2003

Exercise preserves your EDPVR!



Medizinische Universität Graz

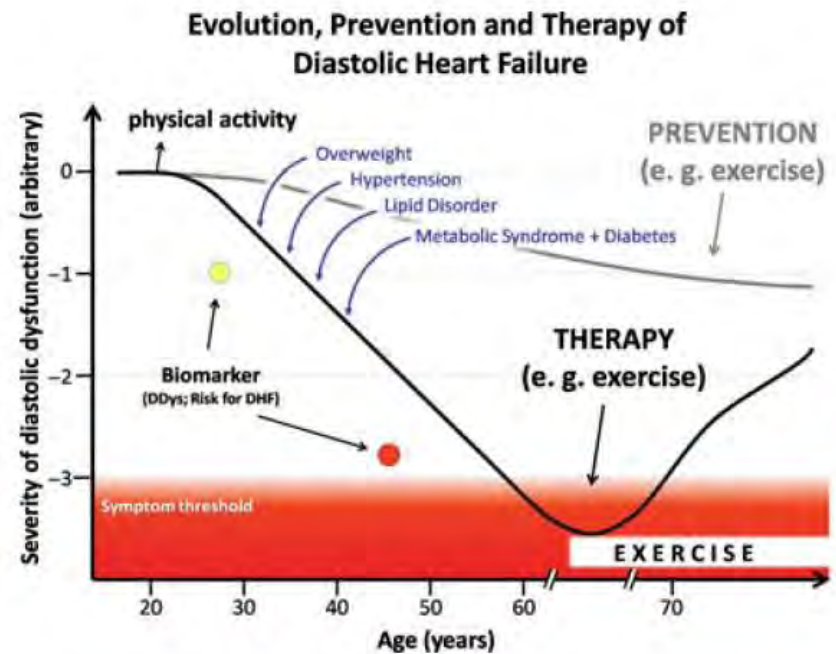
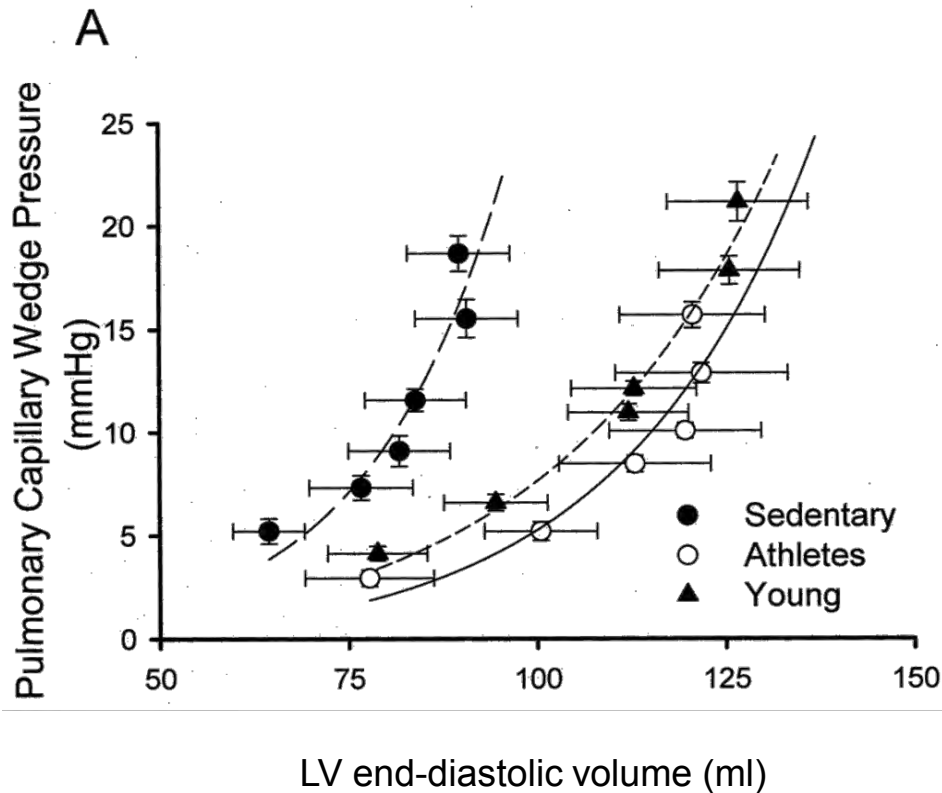

How to model HFPEF? „bedside-to-bench“



Medizinische Universität Graz



RF:

- art. HTN
- obesity
- HLP, diabetes
- sedentary lifestyle



RF:

- DOCA 100 mg/kg/90d
- McDonalds' diet:
 - high lipid/cholesterol
 - 4% salt/ 20% sugar

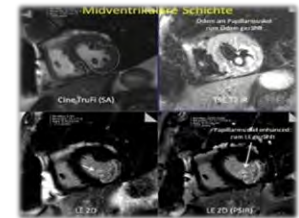
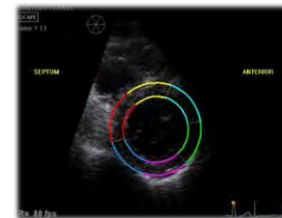
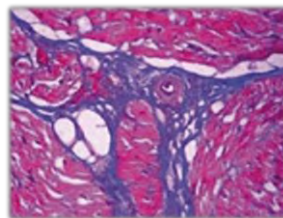
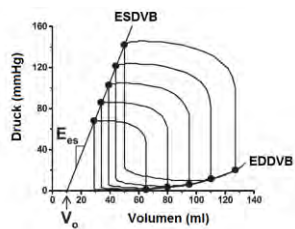

Take home message



Medizinische Universität Graz

HFPEF:

- evolves with accumulating risk factors
- small ventricles with thick walls
- slow relaxation, high end-diastolic pressures
- decreased rotation/suction, aggravated during exercise
- longitudinal LV function summarizes a complex 3-D phenotype
- systemic disease
- high Ea: very sensitive to blood pressure lowering drugs
- no uniform signal transduction
- no definite treatment
- no established experimental models

MH before reperfusion reduces infarct size

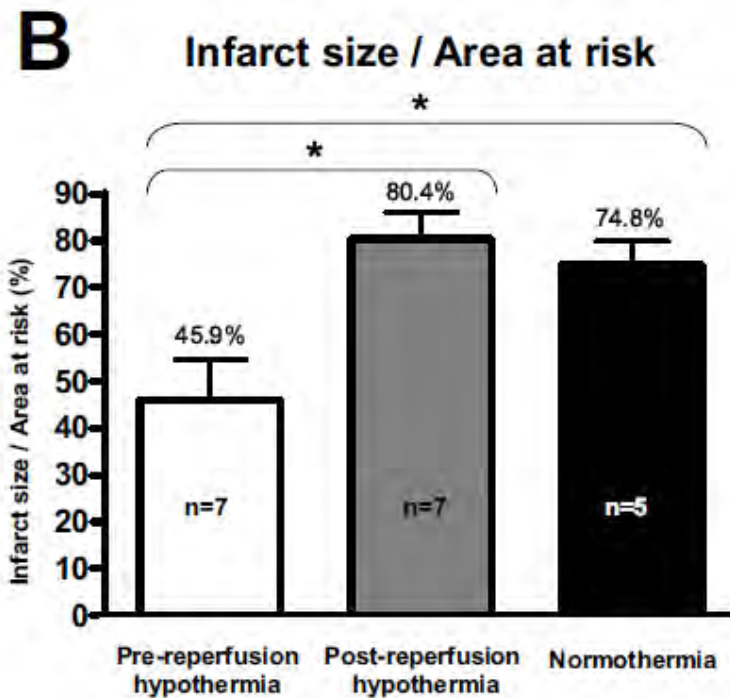
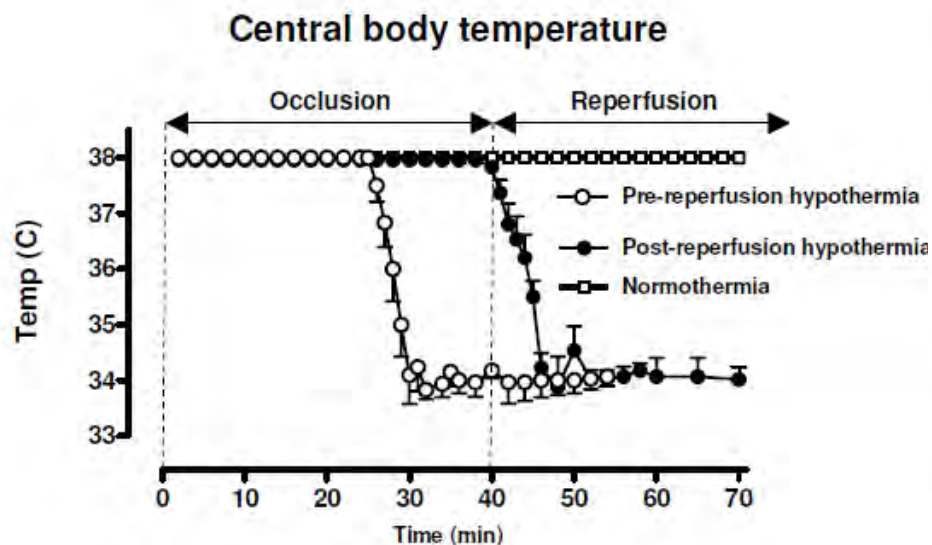
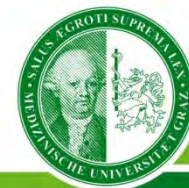

Rapid induction of MH in STEMI patients...



Medizinische Universität Graz

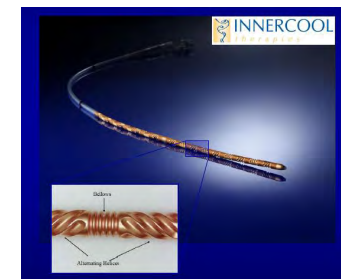
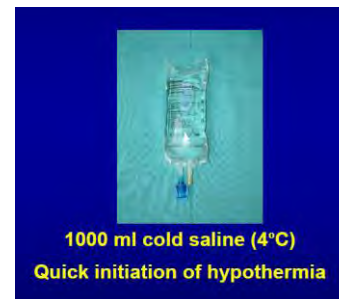
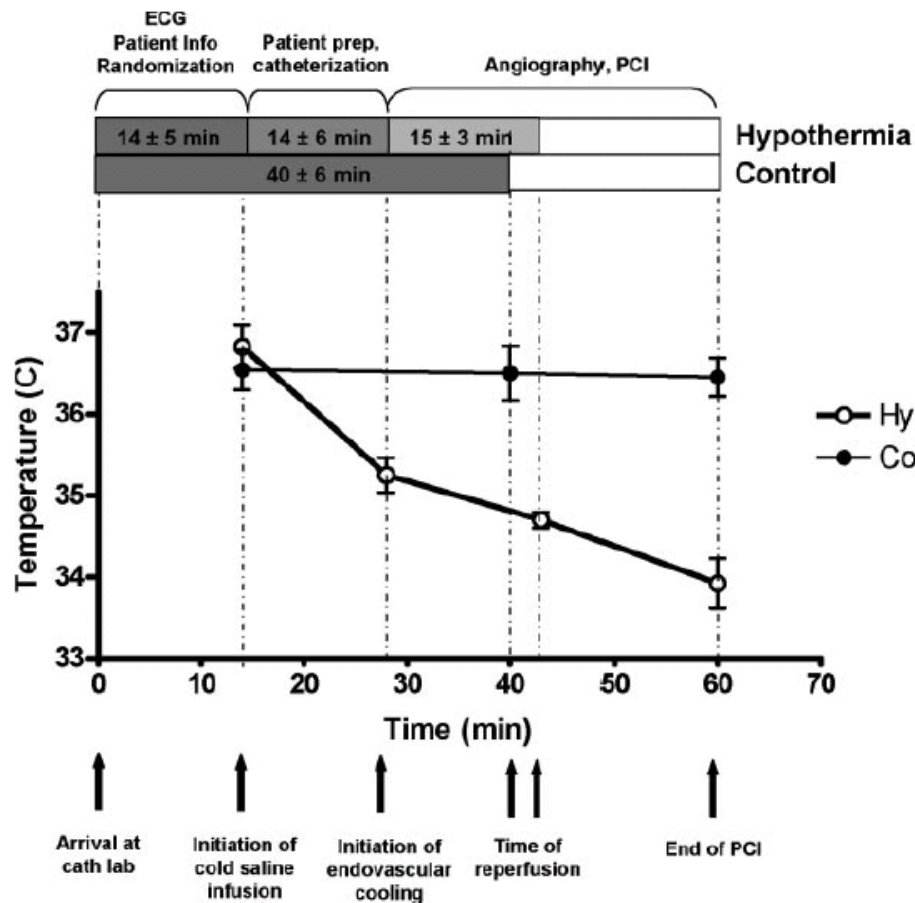

Götberg, Circ CI 2010

...reduces infarct size



time to reperfusion

area-at-risk and infarct size (MRT)

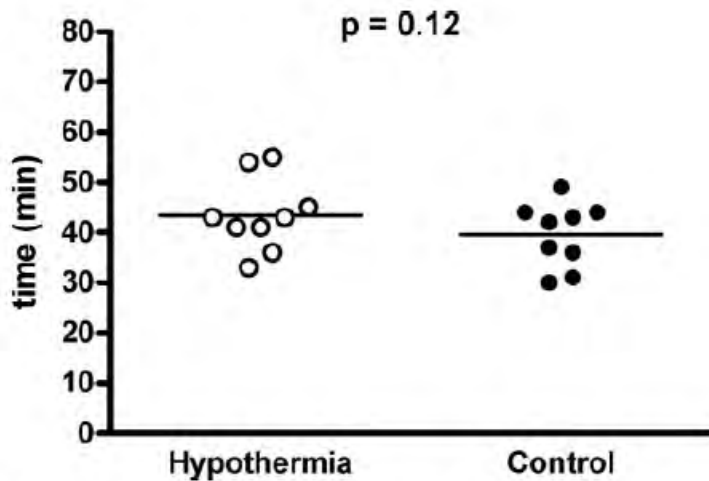
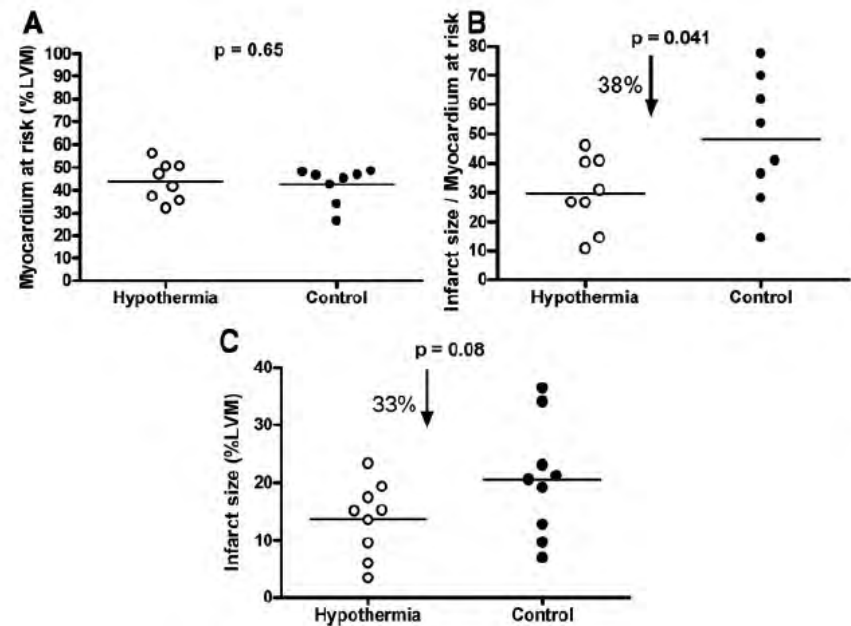

Figure 2. Time from arrival at the hospital until reperfusion (door-to-balloon time). There was no significant delay in reperfusion caused by hypothermia treatment.



MH in normal pigs



Medizinische Universität Graz

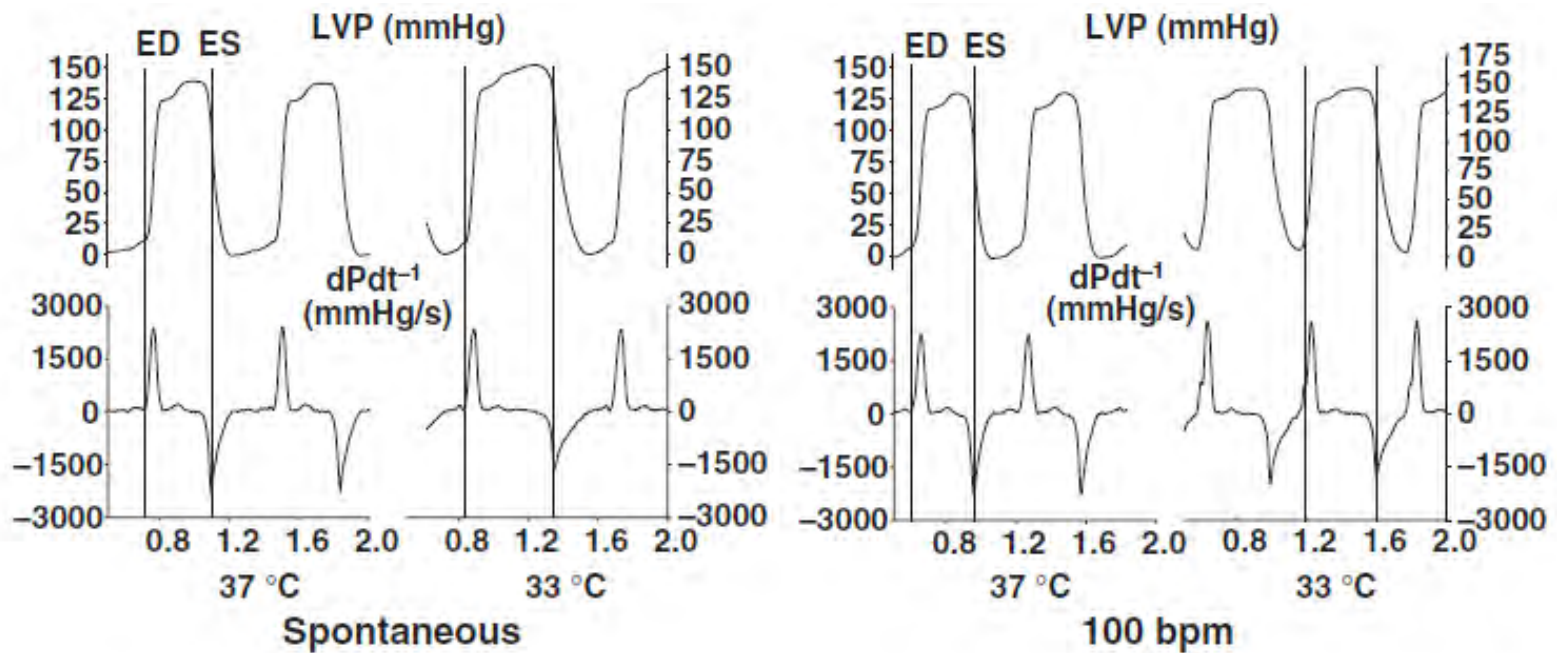

Post et al., Acta Physiol 2010